

IWAKI  
METERING  
PUMPS

**TD-F**



**Low pulsation & High efficient mechanism bring air chamber-free operation and energy saving**

TD series is a mechanically-driven diaphragm pump with twin pump heads.

**Air Chamber - free**

**Wide Control Range**

**Energy Saving**

**Specifications**

Model		01	03	05	1	2	4	6	8	
Max. Discharge capacity	VC/V6/S6 <sup>*1</sup>	L/h	9 (0.15)	18 (0.3)	30 (0.5)	60 (1)	132 (2.2)	246 (4.1)	366 (6.1)	492 (8.2)
	VS <sup>*2</sup>	(L/min)	7.2 (0.12)	14.4 (0.24)	24 (0.4)	48 (0.8)	132 (2.2)	246 (4.1)	366 (6.1)	492 (8.2)
Max. Discharge pressure	MPa	1.0				0.5		0.4		0.3
Flow repeatability		±2%FS								
Flow linearity		±2%FS								
Control range		1:10 (6 to 60Hz)								
Connection	Flange JIS10K	Outlet	15A				25A			
		Inlet	15A				15A VS: 25A	25A		
	Hose	Ø12×Ø18				—				
	Union	VP16				—				
Stroke length	mm	1.2	2.3	1.2	2.3	6				
Stroke rate	spm	12 to 116				7 to 70	12 to 116	9 to 87	12 to 116	
Diaphragm effective diameter	mm	Ø30		Ø60		Ø72		Ø100		
Max suction lift <sup>*3</sup>		1m								
NPSHr	MPaA	0.07		0.08		0.019				
Inertia resistance Pi	MPa/1m	0.001	0.002	0.004	0.007	0.010	0.011	0.019		
Allowable liquid viscosity	VC	300 mPa·s								
	V6	500 mPa·s								
	VS	300 to 1000 mPa·s								
	S6	500 mPa·s or less				1000 mPa·s				
Weight <sup>*4</sup>	VC/V6/VS	26		27		30		35		
	S6	30		32		35		43		
Standard motor		3Phase, Totally-enclosed fan-cooled Outdoor type, Output 0.4kW/4P, Voltage 200/220/400/440V, 60Hz, Insulation class E								
Standard inverter		Output 0.4kW, Voltage 200/400V								

<sup>\*1</sup> Represents the discharge capacity based on pumping clean water at 25°C and the max discharge pressure, and may increase as the pressure reduces.

<sup>\*2</sup> The above information is based on operation with silicone oil (Newtonian liquid) of 1000mPa·s at 25°C with our plumbing system and may change with plumbing conditions or when a different liquid is used. When liquid viscosity gets lower, a flow rate increases and repeatability becomes worse.

<sup>\*3</sup> Represents the allowable highest lift with clean water at 25°C in a suction lift application.

<sup>\*4</sup> Represents the total weights of the pump unit plus the motor unit.

**Dimensions (mm)**

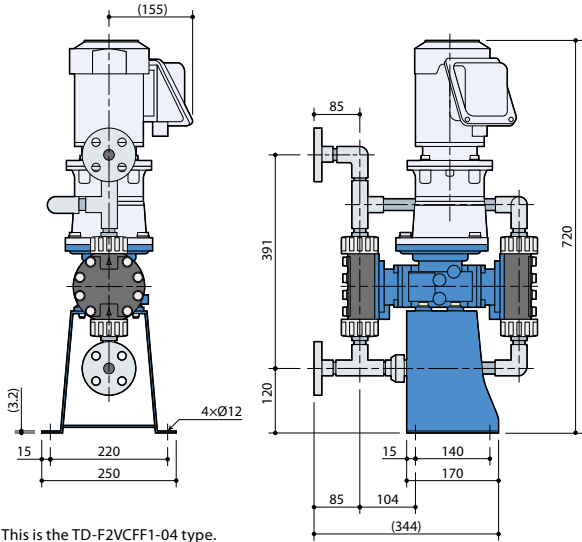

This is the TD-F2VCCF1-04 type. Please contact us for details.

**Figure of recommended plumbing**

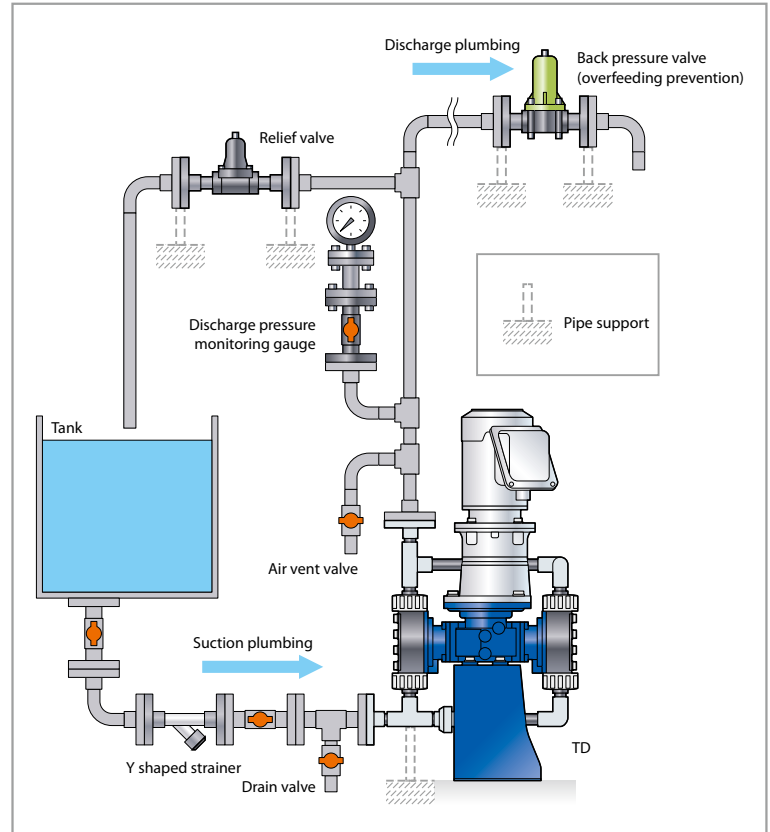

**Accessories**

**Relief valve**

Automatically opens for depressurization of the discharge line when the set pressure is exceeded.



RV/BV-3 type with PVC wet ends

**Selection table**

Wet-end Materials	Model codes	Max. capacity L/min	Set pressure MPa	Connections JIS10K flange	Weight kg
PVC	RV-3P-15	3.0	0.3 to 1.0	15A	0.6
	RV-3P-20			20A	0.6
	RV-3P-25			25A	0.9
	RV-7V-20	7.5	0.3 to 0.8	20A	3.0
	RV-7V-25			25A	3.5
	RV-7VB-20			20A	3.0
	RV-7VB-25	25	0.3 to 1.0	25A	3.5
	RV-25V-25			25A	3.5
	RV-25V-40			40A	4.0
	RV-25V-50	50A	4.6		
SUS316 SCS14	RV-2S6-15	2.0	0.3 to 0.8	15A	3.5
	RV-2S6B-15			15A(JIS16K)	3.5
	RV-7S6-25			25A	6.0
	RV-7S6B-25	7.5	0.3 to 0.8	25A	6.0
	RV-25S6-25			25A(JIS16K)	6.0
	RV-25S6-40			25A	7.5
	RV-25S6B-40	25	0.3 to 0.8	40A	7.5
	RV-25S6B-25			25A	7.5

\* A PTFE diaphragm is used for all the RVs.

**Back pressure valve**

Positioned close to an injection point on the discharge line for the prevention of overfeeding or siphonage.

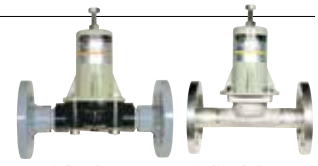

RV/BV-7/-25 type with PVC wet ends

RV/BV-2/-7/-25 type with SUS wet ends

**Selection table**

Wet-end Materials	Models	Flow rate L/min	Set pressure MPa	Connections JIS10K flange	Weight kg
PVC	BV-3P□-12H	0.03 to 3.0	0.1 to 0.8	Ø12xØ18 hose	0.4
	BV-3P-15			15A	0.6
	BV-3P-20			20A	0.9
	BV-3P-25	0.2 to 7.5	0.05 to 0.8	25A	3.5
	BV-7V-20			20A	3.5
	BV-7V-25			25A	4.0
	BV-25V-25	2 to 25	0.1 to 0.8	40A	4.6
	BV-25V-40			50A	4.6
	BV-25V-50			50A	4.6
	SUS316 SCS14	BV-2S6-15	0.02 to 2.0	0.05 to 0.8	15A
BV-7S6-25		25A			6.0
BV-25S6-25		2 to 25	0.1 to 0.8	25A	7.0
BV-25S6-40				40A	7.5
BV-25S6-50				50A	8.7

- The code in the □ field represents an O ring material (E: EPDM V; FKM)
- A PTFE diaphragm is used for all the BVs
- A back pressure valve will not break discharge line flow at the time of the stop of pump. Install a shutoff valve to break the flow completely.

IWAKI CO., LTD. 6-6 Kanda-Sudacho 2-chome Chiyoda-ku Tokyo 101-8558 Japan TEL: (81)3 3254 2935 FAX: 3 3252 8892

IWAKI has global net work. Please find your distributor location at [www.iwakupumps.jp](http://www.iwakupumps.jp)

European office : IWAKI Europe GmbH  
 Germany : IWAKI Europe GmbH  
 Holland : IWAKI Europe GmbH (Netherlands Branch)  
 Italy : IWAKI Europe GmbH (Italy Branch)  
 Spain : IWAKI Europe GmbH (Spain Branch)  
 Belgium : IWAKI Belgium N.V.  
 Denmark : IWAKI Nordic A/S  
 Finland : IWAKI Suomi Oy  
 France : IWAKI France S.A.  
 Norway : IWAKI Norge AS  
 Sweden : IWAKI Sverige AB  
 U.K. : IWAKI Pumps (UK) Ltd.

TEL: (49)2154 9254 0 FAX: 2154 9254 48  
 TEL: (49)2154 9254 50 FAX: 2154 9254 55  
 TEL: (31)74 2420011 FAX: (49)2154 925448  
 TEL: (39)0444 371115 FAX: 0444 335350  
 TEL: (93)93 37 70 198 FAX: 93 47 40 991  
 TEL: (32)13 67 02 00 FAX: 13 67 20 30  
 TEL: (45)48 24 2345 FAX: 48 24 2346  
 TEL: (358)9 2745810 FAX: 9 2742715  
 TEL: (33)1 69 63 33 70 FAX: 1 64 49 92 73  
 TEL: (47)23 38 49 00 FAX: 23 38 49 01  
 TEL: (46)8 511 72900 FAX: 8 511 72922  
 TEL: (44)1743 231363 FAX: 1743 366507

U.S.A. : IWAKI America Inc.  
 Argentina : IWAKI America Inc. (Argentina Branch)  
 Brasil : IWAKI Do Brasil Comercio De Bombas Hidraulicas Ltda.  
 Singapore : IWAKI Singapore Pte Ltd.  
 Indonesia : IWAKI Singapore (Indonesia Office)  
 Malaysia : IWAKIm Sdn. Bhd.  
 Australia : IWAKI Pumps Australia Pty Ltd.  
 Hong Kong : IWAKI Pumps Co., Ltd.  
 China : GFTZ IWAKI Engineering & Trading Co., Ltd.  
 Korea : IWAKI Pumps (Shanghai) Co., Ltd.  
 Taiwan : IWAKI Korea Co., Ltd.  
 Thailand : IWAKI Pumps Taiwan Co., Ltd.  
 Thailand : IWAKI (Thailand) Co., Ltd.

TEL: (1)508 429 1440 FAX: 508 429 1386  
 TEL: (54)11 4745 4116  
 TEL: (55)19 3244 5900 FAX: 19 3244 5900  
 TEL: (65)6316 2028 FAX: 6316 3221  
 TEL: (62)21 6906606 FAX: 21 6906612  
 TEL: (60)3 7803 8807 FAX: 3 7803 4800  
 TEL: (61)2 9899 2411 FAX: 2 9899 2421  
 TEL: (852)2607 1168 FAX: 2607 1000  
 TEL: (86)20 84350603 FAX: 20 84359181  
 TEL: (86)21 6272 7502 FAX: 21 6272 6929  
 TEL: (82)2 2630 4800 FAX: 2 2630 4801  
 TEL: (886)2 8227 6900 FAX: 2 8227 6818  
 TEL: (66)2 322 2471 FAX: 2 322 2477

Caution for safety use: Before use of pump, read instruction manual carefully to use the product correctly.

Legal attention related to export.

Our products and/or parts of products fall in the category of goods contained in control list of international regime for export control. Please be reminded that export license could be required when products are exported due to export control regulations of countries.

The posting and copying from this catalogue without permission is not accepted firmly.