

IWAKI
MAGNETIC
DRIVE
PUMPS

MX



Patent

JAPAN / U.S.A. / EU / CHINA / TAIWAN

Solutions for chemical handling applications

Even better dry-running resistance Iwaki MX magnetic



Self-radiating structure (PAT.)

Through heat-dispersion holes provided in the fixed portions of the impeller and the magnet capsule, liquid is circulated under pressure between the spindle and bearing to reduce friction heat transmission and prevent thermal deformation.

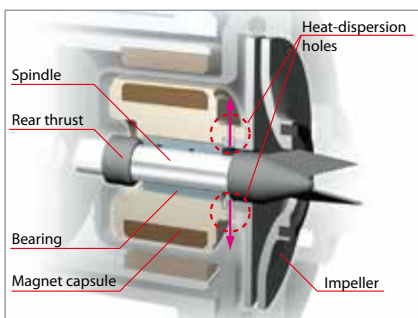

Non-contact structure

The drive magnet and driven magnet are carefully positioned so that their strong magnetic field limits rear thrust contact of the magnet capsule parts, even during dry running. As a result, heat generation is greatly reduced and liquid circulation is maintained. (Except MX-70, 100)

Volute casing divided into two sections (PAT.)

The MX series is the first resin magnet pump which uses the pump casing divided into the front casing and the rear casing to form a vortex chamber as an ideal form. Therefore, internal leakage is kept to a minimum and overall hydraulic efficiency is enhanced.

(Except MX-70, 400, 505)

Robust structure

All stress bearing portions, such as the front and rear casings, are reinforced by means of ribs to improve the pressure resistance and the mechanical strength of the pump.

The bearing is not only fixed by conventional press fit but is also sandwiched between the abutting portion in the depth of the magnet capsule and the rear end of the impeller to improve its reliability under high temperature.

(Except MX-70, 100)

MX-402(H), 403(H) and 505 models: an unplugging preventive lock pin is adopted for ensuring more steady securing.



Front casing



Rear casing



Front casing of type 100 and 402/403

nce and efficiency than previous models. drive pumps - reliable & energy efficient.

The MX Series represents the latest state of the art design in plastic magnetic drive pumps to meet the most severe of operating conditions. When fitted with a carbon bearing the MX will allow for brief periods of dry running. The new "self radiating structure" (PAT.) in addition to the existing proven non contact principle and front and rear supported spindle greatly improves the pumps ability to withstand some cavitation and running against closed discharge valve. Our innovative design has achieved higher efficiency. MX series pumps are highly recommended for use in various production processes such as filtering, spraying, washing and etching in surface treatment processes.

- An improved mechanical strength design allows operation under abnormal conditions and results in reduction of running cost and maintenance cost.
- The split-volute casing significantly improves efficiency over previous versions.
- Simple yet robust construction allows easy maintenance.
- Enhanced intake features and pump efficiency (PAT.) (MX-505)
- Lap joint construction

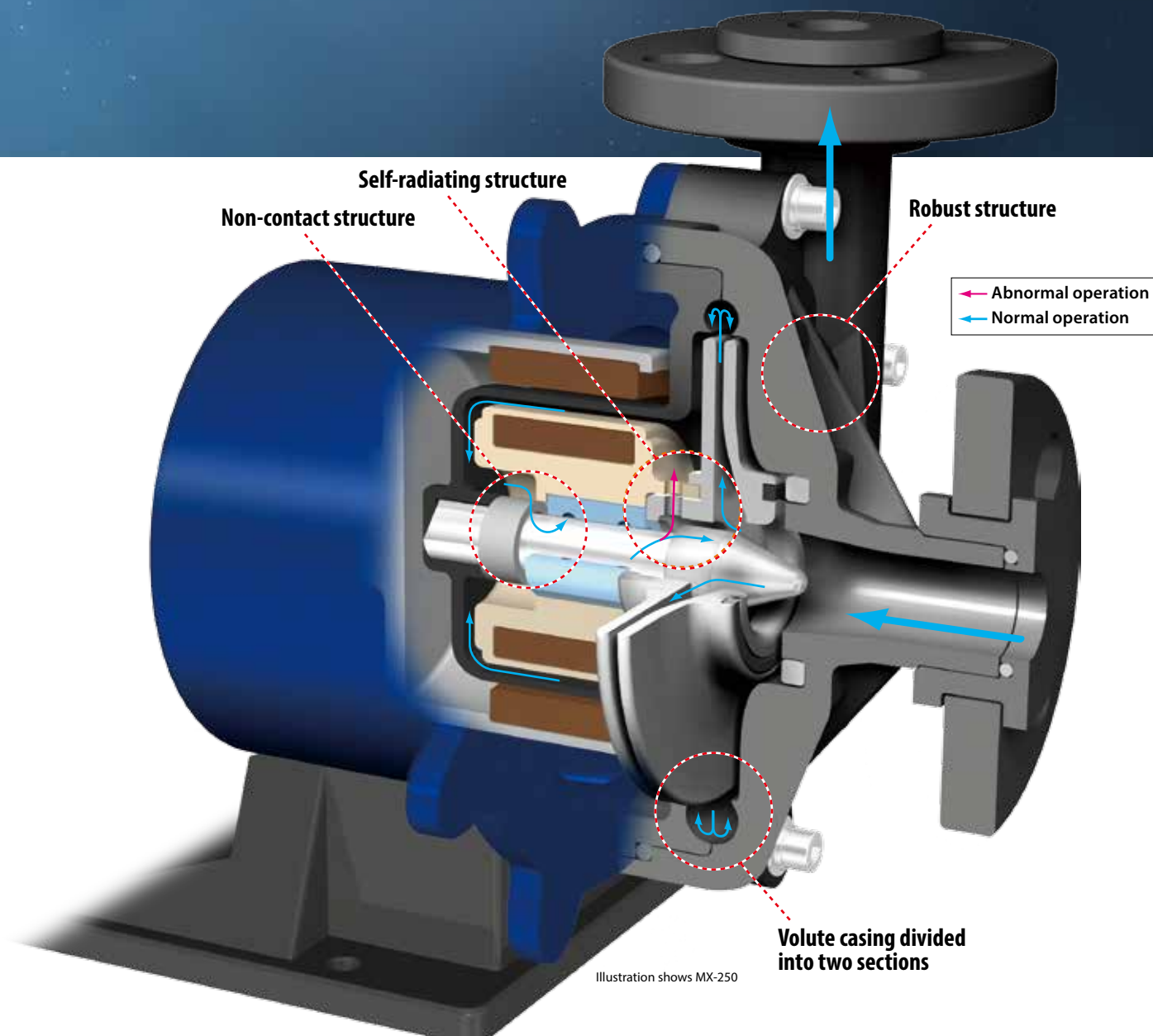



MX-505

MX-403

Wet end materials

■ MX-70,100

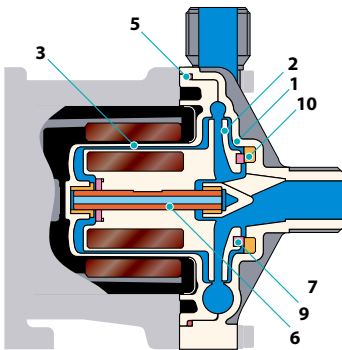

Model	MX-70	MX-100
Mark	V(E)	
1 Front casing	GFRPP	
2 Impeller	CFRPP	
3 Rear casing	GFRPP	
5 O ring	FKM(EPDM)	
6 Spindle	Alumina ceramic	
7 Bearing	CFRPPS	PTFE(with filler)
9 Mouth ring	-	PTFE(with filler)
10 Thrust/Liner ring	Alumina ceramic	

Note: An O-ring made of AFLAS® is also available

■ MX-250 to 401

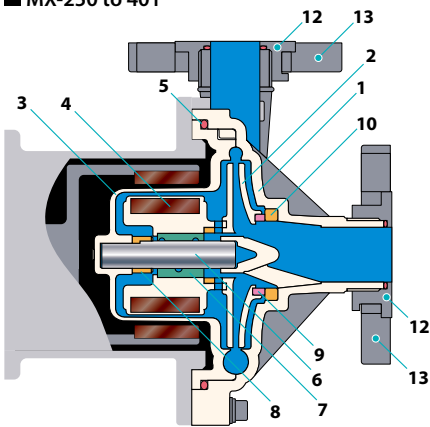

■ MX-402 to 403H

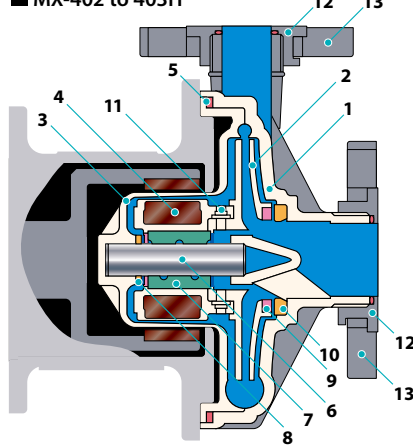

■ MX-505

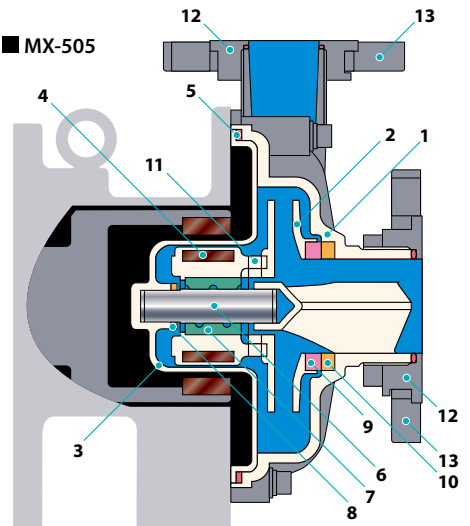

Model	MX-250 to 505		MX-250 to 401
	CV(CE)	RV(RE)	AV(AE)
1 Front casing	GFRPP		
2 Impeller	GFRPP		
3 Rear casing	GFRPP		
4 Magnet capsule	PP		
5 O ring	FKM(EPDM)		
6 Spindle	High purity alumina ceramic		
7 Bearing	Carbon	PTFE(with filler)	Alumina ceramic
8 Rear thrust	CFRPPS (MX-402 to 505: CFRPEEK)		
9 Mouth ring	PTFE(with filler)		
10 Thrust/Liner ring	Alumina ceramic		
11 Lock pin	GFRPPS(Only available type 402 to 505)		-
12 Inner flange	GFRPP		
13 Outer flange	GFRPP		

Note: An O-ring made of AFLAS® is also available



Pump identification

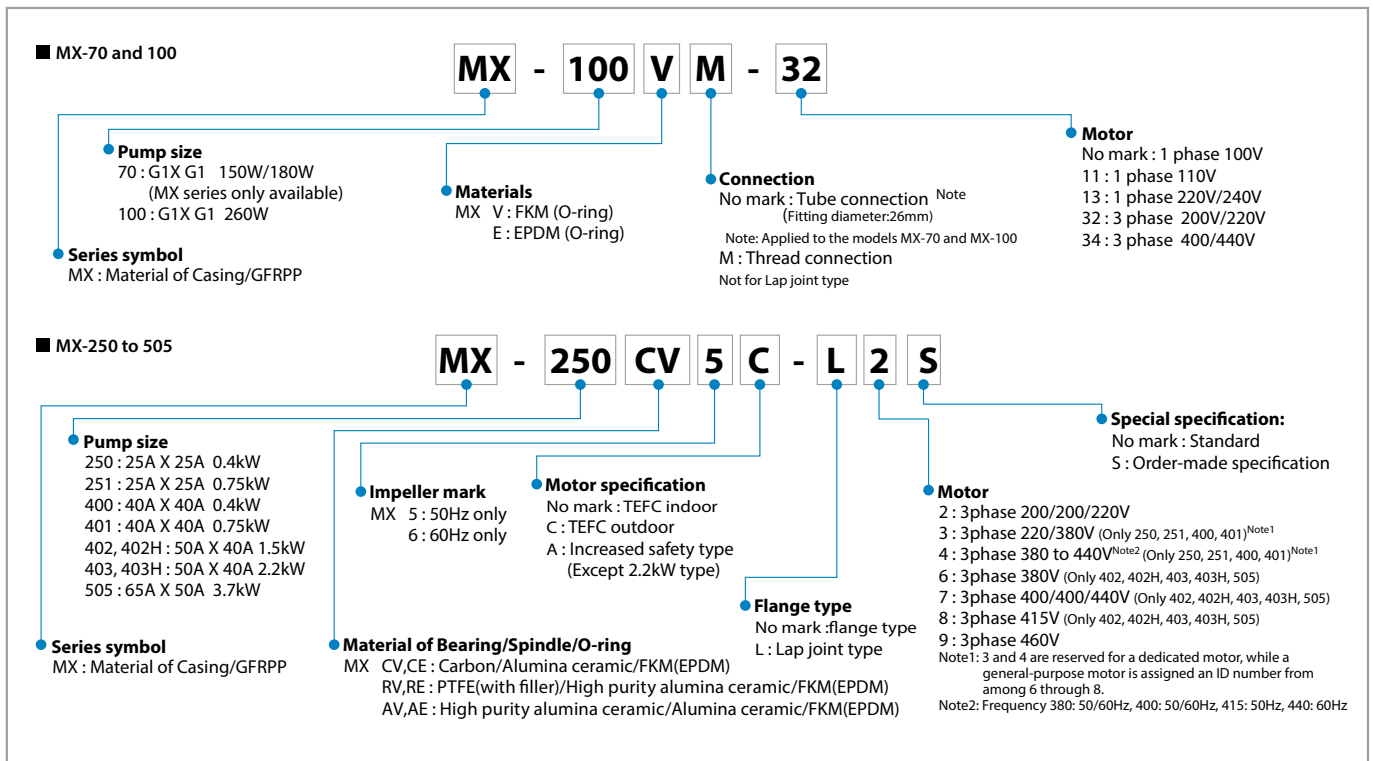

Specifications

50/60Hz

Model	Connection Suction X Discharge	Limit of specific gravity	Standard capacity L/min - m	Maximum capacity L/min	Motor kW	Mass kg
MX-70M	G1 x G1	1.2	50 - 5.4 / 7.8	90 / 100	0.15 / 0.18	6.5
MX-100M			70 - 6 / 9	110 / 125		
MX-250	25A x 25A	1.0	50 - 14 / 13.5	150	0.4	13.5
MX-251			80 - 19		0.75	22
MX-400	40A x 40A	1.2	100 - 10.5 / 10	280	0.4	13.5
MX-401			150 - 14.5	320	0.75	22
MX-402	50A x 40A	1.2	200 - 20/19.5	450	1.5	38
MX-402H		1.0	100 - 30	160		
MX-403	50A x 40A	1.2	250 - 23 / 25	500	2.2	43
MX-403H		1.0	100 - 35 / 36	300 / 250		
MX-505	65A x 50A	1.2	500 - 24.5 / 23.5	800	3.7	64

Note1: The specific gravity limit varies with the discharge. For details, please contact us.

Note2: 26mm tube connection option available on the MX-70 and MX-100.

Note3: AV(AE) type is different in discharge capacity. For details, please contact us.

Common specifications

• Range of liquid temperature : 0 to 80°C (10 to 80°C in case AFLAS® O-rings are used.) • Range of ambient temperature : 0 to 40°C.

Performance curves

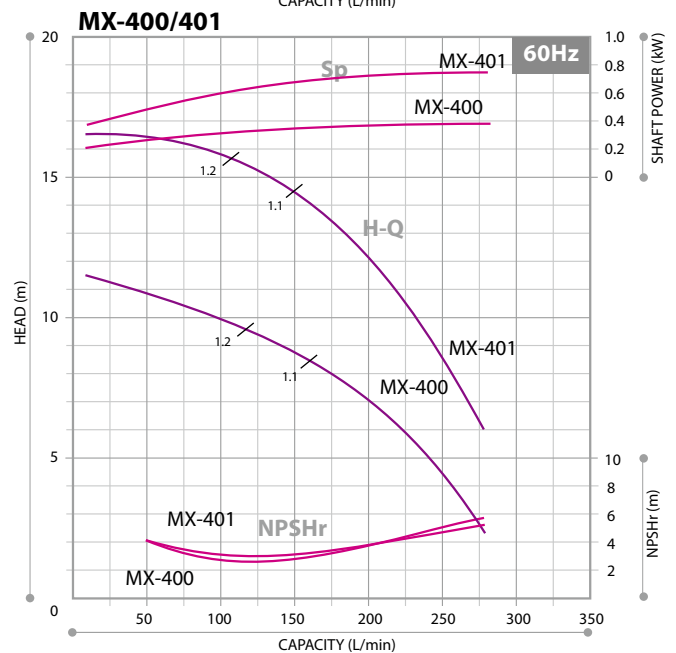
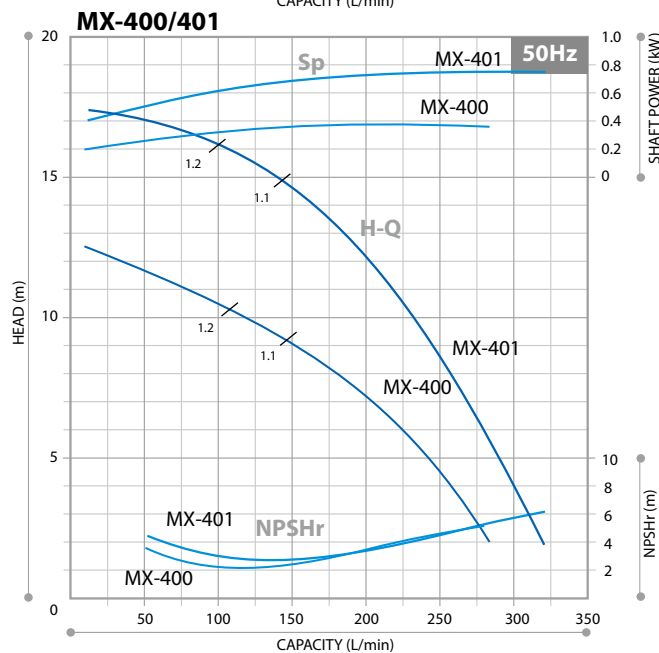
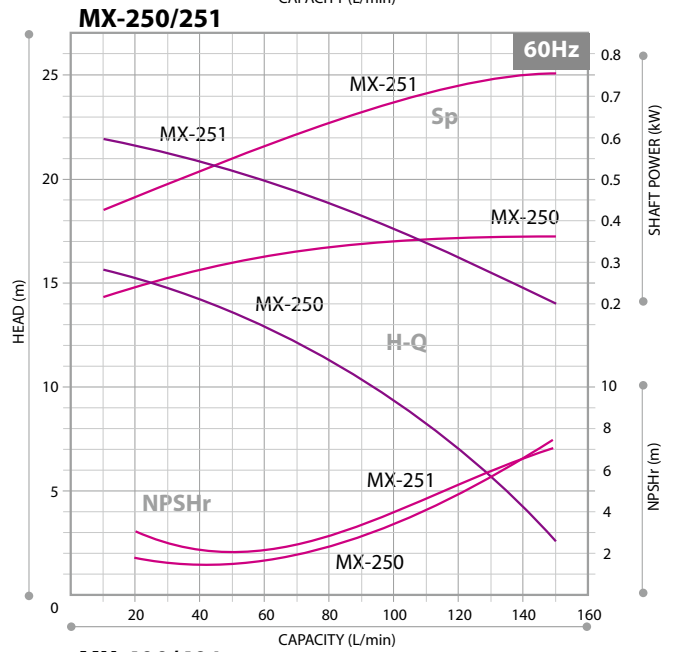
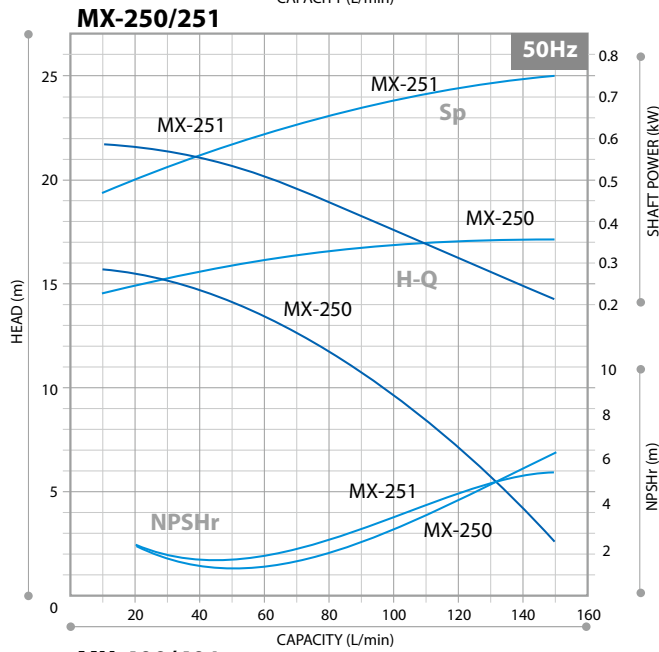
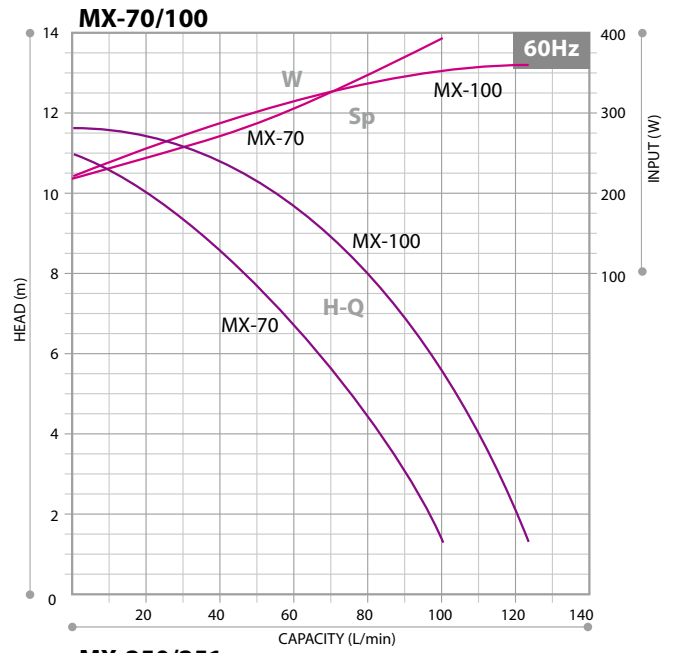
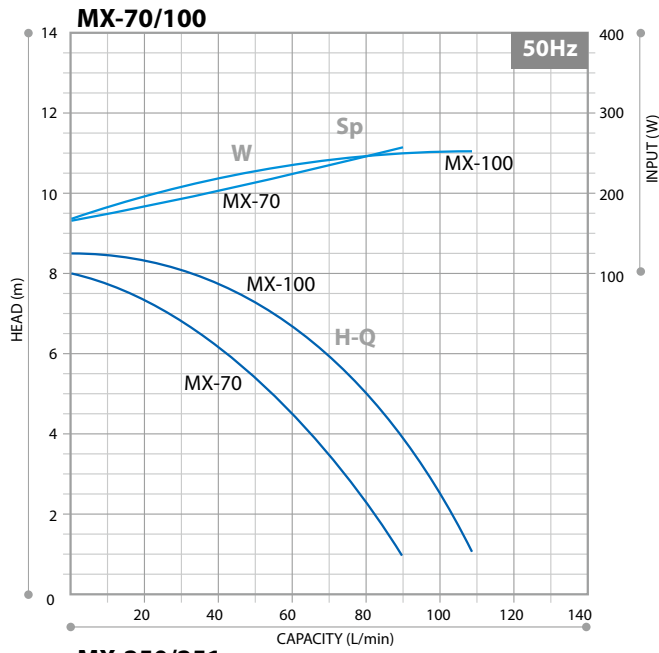

Performance curves

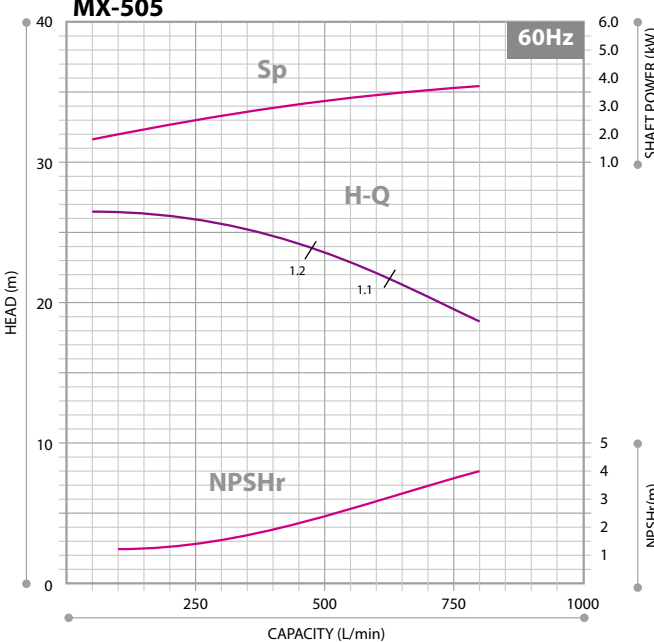
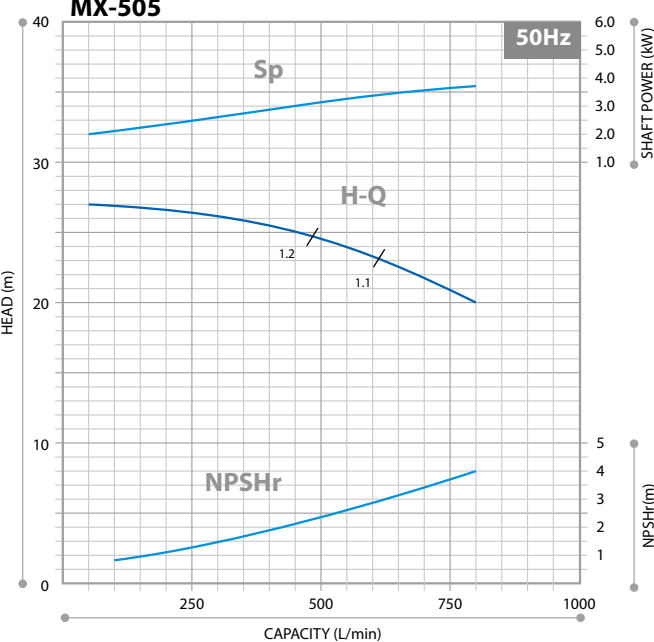
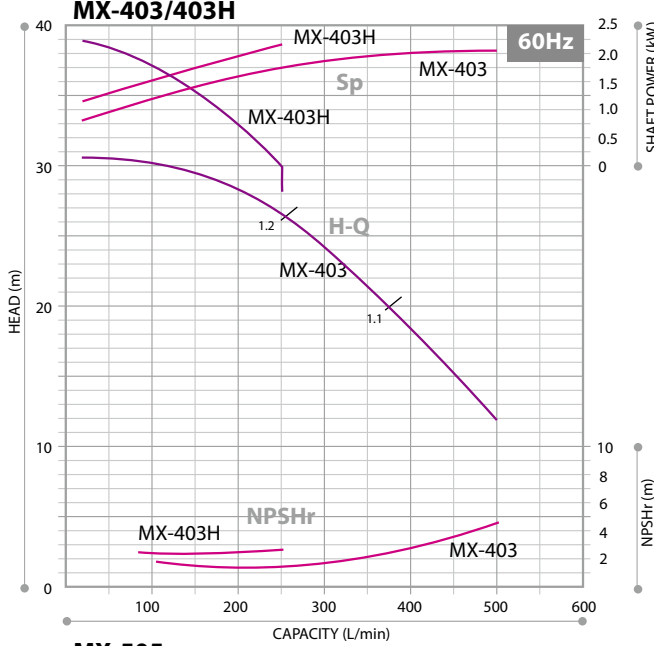
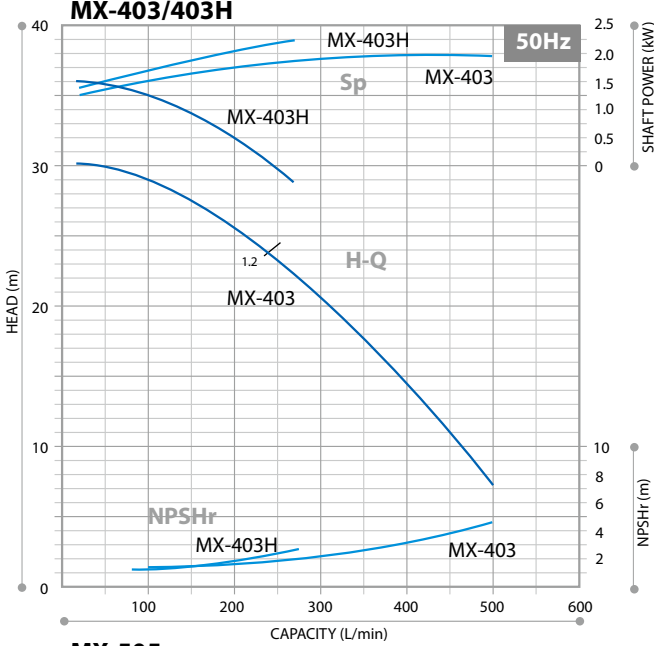
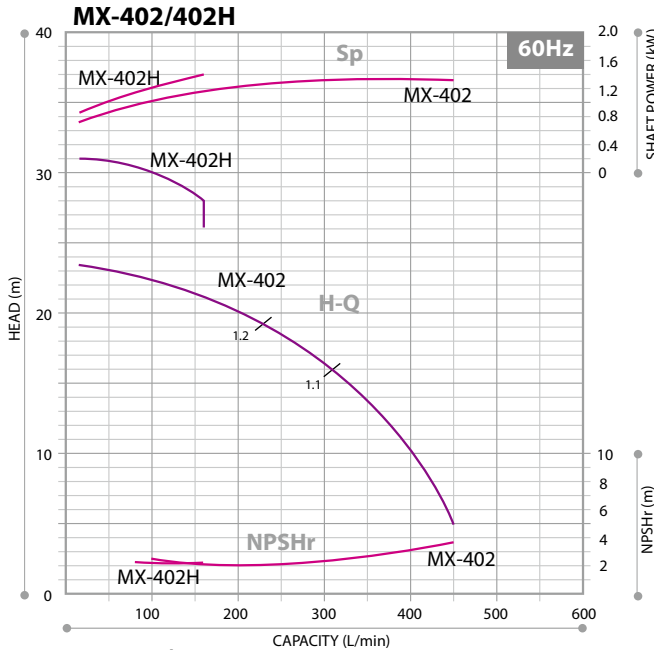
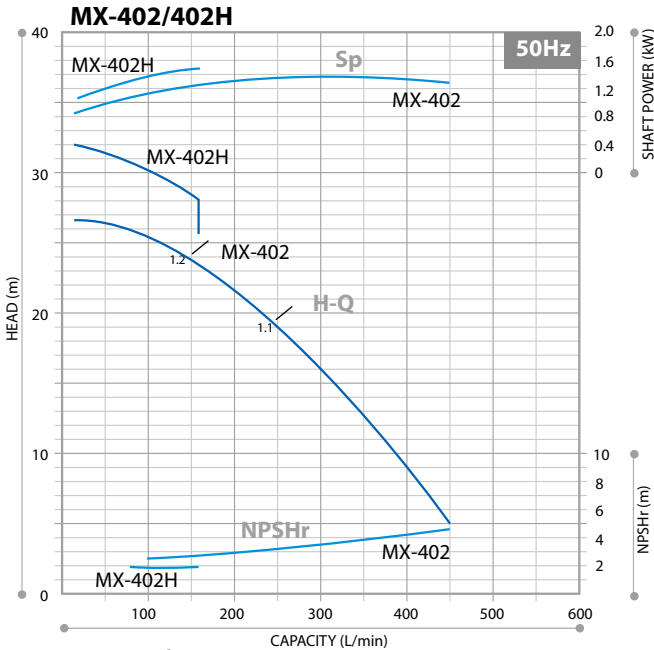

Dimensions

MX-70, 100

Note

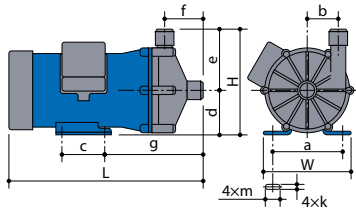

MX-250 to 401

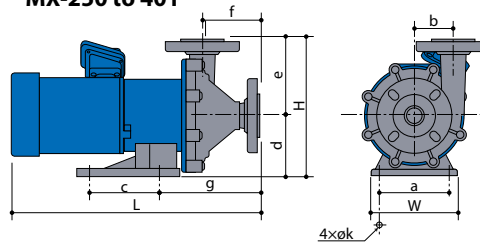

MX-402, 402H, 403, 403H

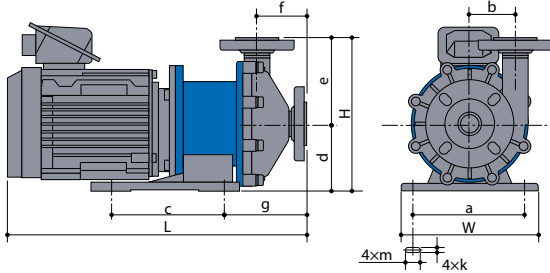

MX-505

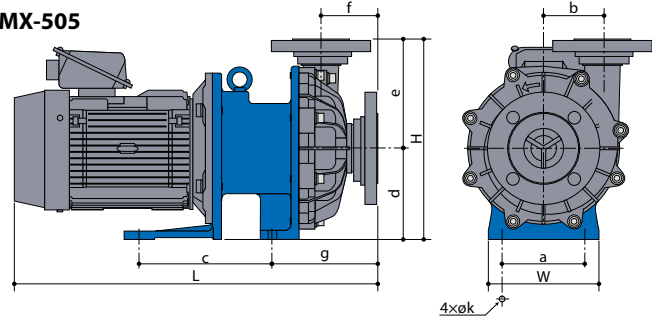

Models	W	H	L	a	b	c	d	e	f	g	k	m
MX-70	130	155	258.5	110	48	40	65	90	53	159.5	7	11
MX-100	150	175	319.5	110	51	70	75	100	65	162	9	27
MX-250	160	255	411	130	65	130	115	140	90	163	12	—
MX-251	160	255	446	130	65	130	115	140	90	171	12	—
MX-400	140	225	411	110	54	98	95	130	87	150	12	—
MX-401	160	255	459	130	72	130	115	140	103	184	12	—
MX-402,402H	260	280	514	208	80	200	120	160	89	157	14	36
MX-403,403H	260	280	543	208	80	200	120	160	89	157	14	36
MX-505	180	330	601	140	96	220	150	180	95	175	14	—

Note: MX-70 and MX-100 show thread type in the above dimensions, Please contact us for tube connection type.
 • The dimensions may differ with the type of motor installed.

Optional accessories

Iwaki pump protector DRN series

Detects unusual pump operating conditions including dry-running and overload

The DRN model protects equipment (including pumps) from damage! Minimizes production downtime. Identifies possible causes of alarms so they can be investigated and addressed.



- Multiple Input: Two analog, one digital, one temperature input and one current input
- Easy operation: Equipped with EASY setup mode to remember the operation status and set the lower/upper limit values, as well as AUTO setup mode
- Bar graph: Visible indication of current operating status
- Logging capability: Data log feature for preventative maintenance scheduling
- Communication: RS485 external communication capability

Specifications

Model	DRN-01	DRN-02
Amperometric range	0.5-30.00A	5.0-200.0A
Unit's source voltage	AC100-240V 50/60Hz 10VA	
Operating temperature	0-40°C	
Operating humidity	35-85%RH	

Union joint

Special purpose union joints are available. Material : PVC/Heat resistant PVC



IWAKI CO., LTD. 6-6 Kanda-Sudacho 2-chome Chiyoda-ku Tokyo 101-8558 Japan TEL : (81)3 3254 2935 FAX : 3 3252 8892 IWAKI has global net work. Please find your distributor location at www.iwakipumps.jp

European office : IWAKI Europe GmbH Germany : IWAKI Europe GmbH Holland : IWAKI Europe GmbH (Netherlands Branch) Italy : IWAKI Europe GmbH (Italy Branch) Spain : IWAKI Europe GmbH (Spain Branch) Belgium : IWAKI Belgium N.V. Denmark : IWAKI Nordic A/S Finland : IWAKI Suomi Oy France : IWAKI France S.A. Norway : IWAKI Norge AS Sweden : IWAKI Sverige AB U.K. : IWAKI Pumps (UK) Ltd.	TEL: (49)2154 9254 0 FAX: 2154 9254 48 TEL: (49)2154 9254 50 FAX: 2154 9254 55 TEL: (31)74 2420011 FAX: (49)2154 925448 TEL: (39)0444 371115 FAX: 0444 335350 TEL: (34)93 37 70 198 FAX: 93 47 40 991 TEL: (32)13 67 02 00 FAX: 13 67 20 30 TEL: (45)48 24 2345 FAX: 48 24 2346 TEL: (358)9 2745810 FAX: 9 2742715 TEL: (33)1 69 63 33 70 FAX: 1 64 49 92 73 TEL: (47)23 38 49 00 FAX: 23 38 49 01 TEL: (46)8 511 72900 FAX: 8 511 72922 TEL: (44)1743 231363 FAX: 1743 366507	U.S.A. : IWAKI America Inc. Argentina : IWAKI America Inc. (Argentina Branch) Brazil : IWAKI Do Brasil Comercio De Bombas Hidraulicas Ltda. Singapore : IWAKI Singapore Pte Ltd. Indonesia : IWAKI Singapore (Indonesia Office) Malaysia : IWAKIm Sdn. Bhd. Australia : IWAKI Pumps Australia Pty Ltd. Hong Kong : IWAKI Pumps Co., Ltd. China : GFTZ IWAKI Engineering & Trading Co., Ltd. Korea : IWAKI Pumps (Shanghai) Co., Ltd. Taiwan : IWAKI Korea Co., Ltd. Thailand : IWAKI Pumps Taiwan Co., Ltd. Thailand : IWAKI (Thailand) Co., Ltd.	TEL: (1)508 429 1440 FAX: 508 429 1386 TEL: (54)11 4745 4116 TEL: (55)19 3244 5900 FAX: 19 3244 5900 TEL: (65)6316 2028 FAX: 6316 3221 TEL: (62)21 6906606 FAX: 21 6906612 TEL: (60)3 7803 8807 FAX: 3 7803 4800 TEL: (61)2 9899 2411 FAX: 2 9899 2421 TEL: (852)2607 1168 FAX: 2607 1000 TEL: (86)20 84350603 FAX: 20 84359181 TEL: (86)21 6272 7502 FAX: 21 6272 6929 TEL: (82)2 2630 4800 FAX: 2 2630 4801 TEL: (886)2 8227 6900 FAX: 2 8227 6818 TEL: (66)2 322 2471 FAX: 2 322 2477
--	---	---	--

Caution for safety use: Before use of pump, read instruction manual carefully to use the product correctly. Actual pumps may differ from the photos. Specifications and dimensions are subject to change without prior notice. For further details please contact us.

Legal attention related to export. Our products and/or parts of products fall in the category of goods contained in control list of international regime for export control. Please be reminded that export license could be required when products are exported due to export control regulations of countries. The posting and copying from this catalogue without permission is not accepted firmly.