



IWAKI Magnetic Drive Pump

MDH-F (Asia Edition)

Instruction Manual

⚠ Read this manual before use of product

Thank you for selecting an Iwaki MDH-F Series Magnetic Drive Pump. This instruction manual deals with "*Safety instructions*", "*Outline*", "*Installation*", "*Operation*" and "*Maintenance*" sections. Please read through this manual carefully to ensure the optimum performance, safety and service of your pump.

Contents

Important instructions	1
Safety instructions	2
<i>Outline</i>	
1. Unpacking & Inspection	6
2. Product outline	6
3. Model code	7
4. Specification.....	8
5. Dimension	8
6. Part names.....	10
7. Overview	12
<i>Installation</i>	
1. Before installation	14
2. Installation/ Pipework/ Wiring	17
<i>Operation</i>	
1. Operational precautions.....	24
2. Before operation.....	25
3. Operation.....	25
<i>Maintenance</i>	
1. Troubleshooting.....	28
2. Maintenance & Inspection	29
3. Spare & Wear parts	33
4. Dismantlement & Assembly	34



This instruction manual should be kept on hand by the end user for quick reference.

Contact us or your nearest dealer if you have any questions.

Important instructions

For the Safe and Correct Handling of the Pump

- "Safety Instruction" section deals with important details about handling of the product. Before use, read this section carefully for the prevention of personal injury or property damage.
- Observe the instructions accompanied with "WARNING" or "CAUTION" in this manual. These instructions are very important for protecting users from dangerous situations.
- The symbols on this instruction manual have the following meanings:

 WARNING	Nonobservance or misapplication of "Warning" sections could lead to a serious accident which may result in death.
 CAUTION	Nonobservance or misapplication of "Caution" sections could lead to a personal injury or property damage.

Types of Symbols



Indicates that "Warning" or "Caution" must be exercised. Inside this triangle, a concrete and practical image provided as a warning or caution message is depicted.



Indicates a prohibited action or procedure. Inside or near this circle, a concrete and practical image of the activity to be avoided is depicted.



Indicates an important action or procedure which must be performed or carried out without fail. Failure to follow the instructions herein can lead to malfunction or damage to the pump.

Export Restrictions

Technical information contained in this instruction manual might be treated as controlled technology in your countries, due to agreements in international regime for export control. Please be reminded that export license/permission could be required when this manual is provided, due to export control regulations of your country.

Safety instructions

WARNING

- **Turn off power before work**

Be sure to turn off the power before starting maintenance/repair work.

Make sure no one turns on the power while working on the pump, otherwise it may result in a serious accident. Let other people know about the situation by displaying a notice such as "POWER OFF (Maintenance)" near the power switch.



Turning off power

- **Wear protective clothing**

Always wear protective clothing such as eye protection and protective gloves during pipework or dismantlement of the pump.



Wear protective gear

- **Use strong ropes (chains) for lifting up the pump**

Serious injury may result if lifting ropes (chains) break. Check lifting ropes (chains) are strong enough before use. Observe the maximum weight.



Danger

- **Do not remodel the pump**

A remodelled pump will not be warranted. Also, we are not responsible for personal injury or property damage due to modification.



No Remodeling

- **When handling harmful liquid**

For handling harmful liquids as mentioned below, be sure to conduct daily inspection & maintenance for the prevention of liquid/gas leakage.

1. Explosive or flammable liquid
2. Corrosive liquid
3. Health hazardous liquid



Safety instructions

CAUTION

- **Restriction on pump operator**

The pump must be handled or operated by a qualified person with a full understanding of the pump.



Prohibited

- **For a specified application only**

Use of the pump in any application other than those clearly specified may result in personal injury or property damage.



Prohibited

- **For a specified power only**

Do not apply any voltage other than the specified one on the motor nameplate. Otherwise, damage or fire may result.



Prohibited

- **Ventilation**

Poisoning may result when handling a harmful liquid. Keep good ventilation in your work area.



- **Countermeasure against efflux**

Take protective measures against accidental chemical efflux and splash at pump or piping breakage. Do not allow an outflow to directly soak into the ground.



- **Do not run pump dry**

Do not run pump dry (Operation without liquid). Friction heat builds up during dry running operation and damages internal parts. If the pump is operated with a suction side valve closed or without priming, the pump runs dry.



Prohibited

- **Do not bring the pump close to a flammable substance**

Keep the pump away from a flammable substance for the prevention of fire.



Fire ban

- **Do not stand on the pump**

Do not use the pump as a platform. Injury or damage may result when the pump turns over.



Prohibited

- **Do not lift the pump by gripping any plastic parts (pump unit, flange or base)**

The pump can drop unintentionally as a plastic part breaks, resulting in serious injury. Rope or chain the motor to lift up the pump horizontally.



Prohibited

- **Do not touch the pump or a pipe**

Hot surface temperature. Do not touch the pump or a pipe with bare hands during or right after hot liquid transfer. Take preventative measures against burn.



Prohibited

Safety instructions

CAUTION

• Earthing

Risk of electrical shock. Do not run the pump without earthing. Secure earth protection to reduce the risk.



Grounding

• Install an earth leakage breaker

Risk of electrical shock. Do not run the pump without a leakage breaker. Secure a leakage breaker to reduce the risk.



• Limitations on working and storage areas

Do not install or store the pump in the following places:

1. Where ambient temperature exceeds 40°C or falls below 0°C.
2. Where ambient humidity exceeds 85%RH or falls below 35%RH.
3. Under a flammable/explosive atmosphere or in a dusty place (Except explosion-proof type).
4. Where the pump is exposed to wind and rain (Except outdoor-use type).
5. Where the pump is subject to vibration.
6. Under a corrosive atmosphere such as chlorine gas.



Prohibited

• Starting

The pump doesn't have an ON-OFF switch. The pump starts as a power cable is plugged in.



Caution

• Foreign matter

When foreign matters enter the pump, turn off power at once and remove them. Using the pump with foreign matters may result in failure.



Caution

• Pump disposal

Any used or damaged pump must be disposed of in accordance with local laws and regulations as an incombustible (Consult a licensed industrial waste products disposing company.).



• Static electricity

When low electric conductivity liquids such as ultra-pure water and fluor inactive liquid (e.g. Fluorinert™) are handled, static electricity may generate in the pump and may cause static discharge. Take countermeasures to remove static electricity.



Static electricity countermeasure

Outline

<i>1. Unpacking & Inspection</i>	<i>6</i>
<i>2. Product outline.....</i>	<i>6</i>
<i>3. Model code</i>	<i>7</i>
<i>4. Specification</i>	<i>8</i>
<i>5. Dimension.....</i>	<i>8</i>
<i>6. Part names</i>	<i>10</i>
<i>7. Overview.....</i>	<i>12</i>

Outline

1. Unpacking & Inspection

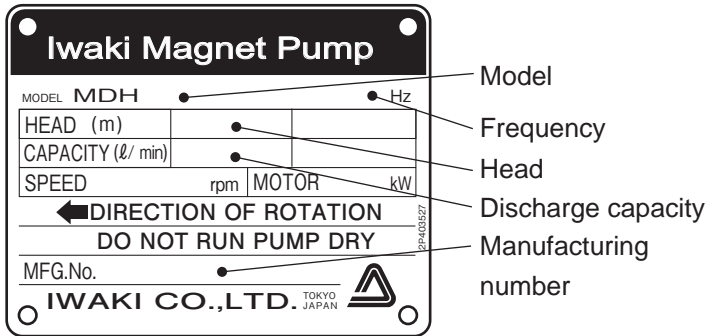

On unpacking the product, check the following points. If you find any problems, contact your nearest distributor.

1. Check the information on nameplate (model code, flow rate, head and voltage) to see if the product is delivered as per order.
2. Check for transit damage, deformation, and loose bolts.
3. A cardboard pad is inserted in the inlet of the MDH-F □ KK type (custom design pumps with SiC sliding parts). Be sure to remove this pad during installation.

2. Product outline

The MDH-F is a magnetic drive centrifugal pump.

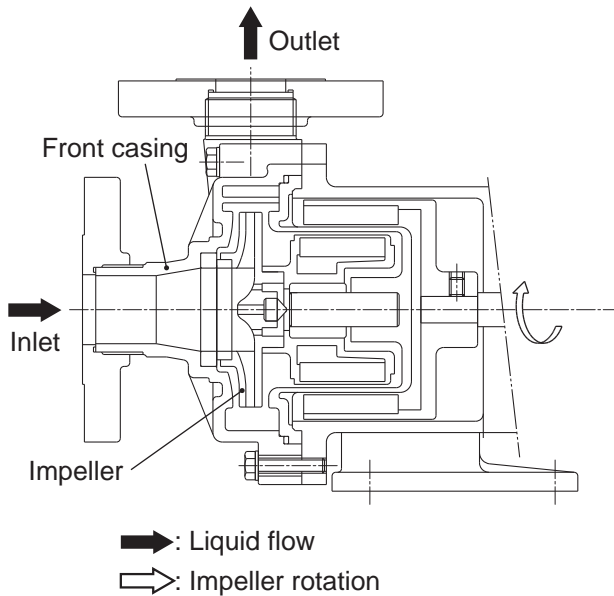

■ Principle of operation

The magnetic force rotates the impeller in the pump chamber (front casing), where a liquid is transferred from the inlet to outlet.

Outline

3. Model code

MDH - F 400 CFV T C - D
a b c d e f

a. Series code: MDH-F series

b. Pump I.D. and motor output

Code	Pump I.D. (Inlet x Outlet)	Motor output
400	40A x 40A	0.4kw
401	40A x 40A	0.75kw
422	50A x 40A	1.5kw
423	50A x 40A	2.2kw

NOTE: The motor is 2-pole, 3-phase.

c. Spindle, bearing and O ring material

Material	CFV	AAV
Spindle	High purity alumina ceramic	Alumina ceramic*
Bearing	High density carbon	
O ring	FKM	

* High purity alumina ceramic for the MDH-F422 and MDH-F423 models.

d. Impellers

T, V, W: 50Hz

X, Y, Z: 60Hz

e. Motors

A: Increased safety motor (MDH-F400/-F401 only)

C: Totally-enclosed-fan-cooled motor for outdoor use

No code: Totally-enclosed-fan-cooled motor for indoor use

f. D: Dry run resistant

E or no code: Dry run prohibited

Outline

4. Specification

Model	Pump I.D. (mm) Inlet x Outlet	Impeller	Motor output (kW)	
MDH-F400	40A x 40A	T / X	0.4	
		V / Y		
		W / Z		
MDH-F401		40A x 40A	T / X	0.75
			V / Y	
			W / Z	
MDH-F422	50A x 40A		T / X	1.5
			V / Y	
			W / Z	
MDH-F423		50A x 40A	T / X	2.2
			V / Y	
			W / Z	

■ Pump weight

Model	MDH-F400	MDH-F401	MDH-F422	MDH-F423
MDH-F	15kg	20kg	32kg	33kg
MDH-F (IE3)	-	23.5kg	39kg	43kg

5. Dimension

MDH-F400/-F401

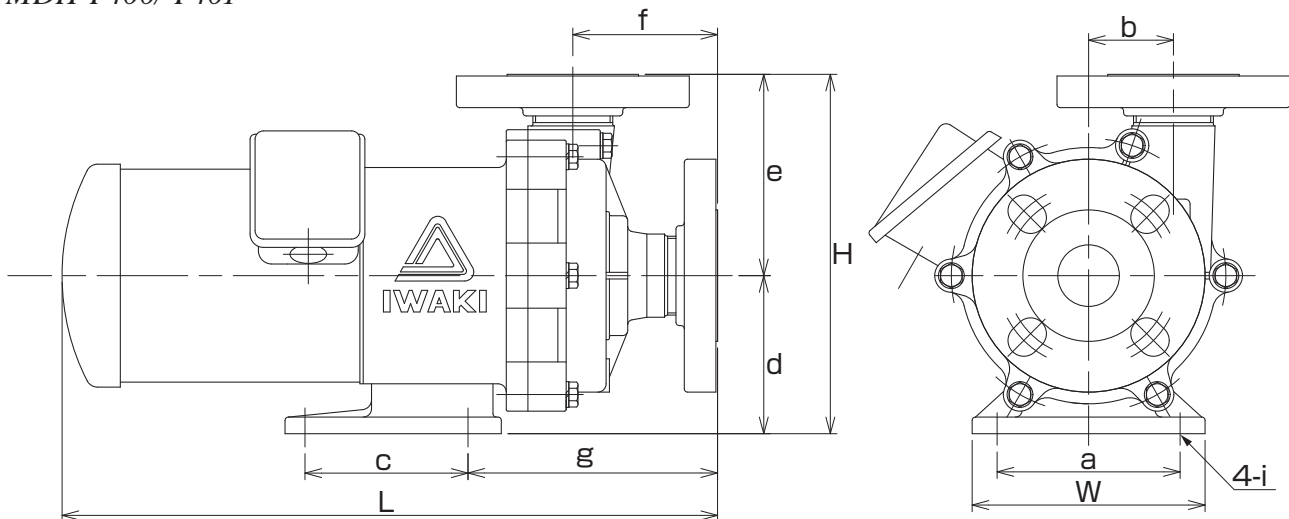

Model	W	H	L	a	b	c	d	e	f	g	i
MDH-F400	140	216	394	110	51	98	95	121	87	150	Ø12
MDH-F401	160	254	494	130	57.5	130	115	139	103	184	
MDH-F401 (IE3)			496								

NOTE: Actual dimensions may differ from the above information depending on model identification codes.

Outline

MDH-F422/-F423

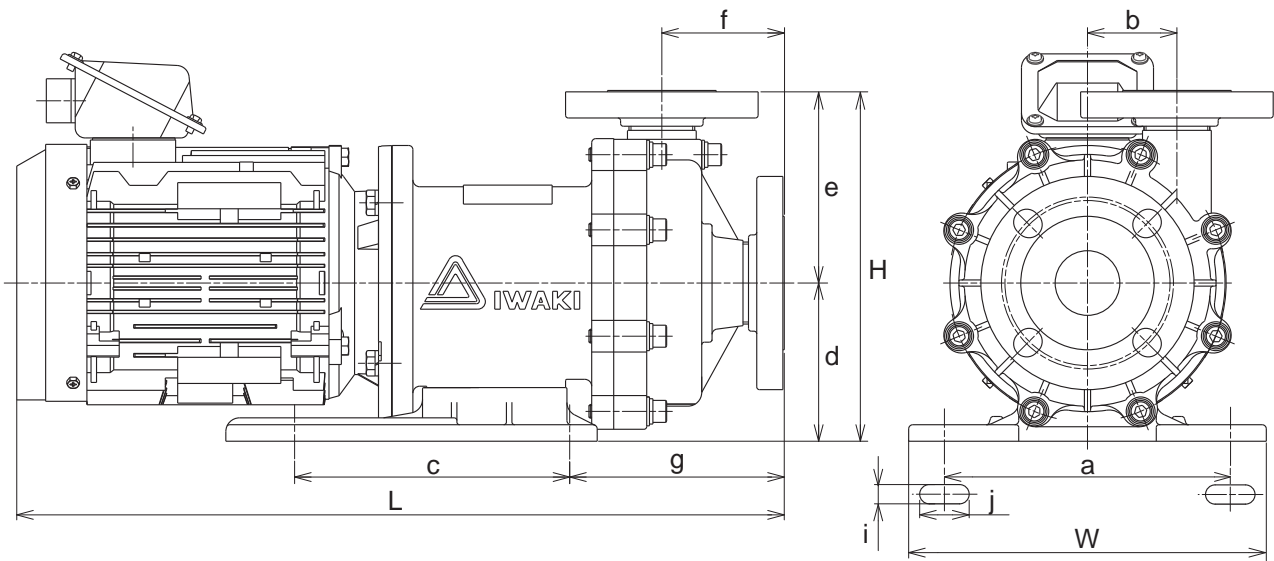

Model	W	H	L	a	b	c	d	e	f	g	i	j
MDH-F422/-F423	260	255	539	208	65	200	115	140	89	156	14	36
MDH-F422/-F423 (IE3)			558/587									

Outline

6. Part names

MDH-F400/-F401

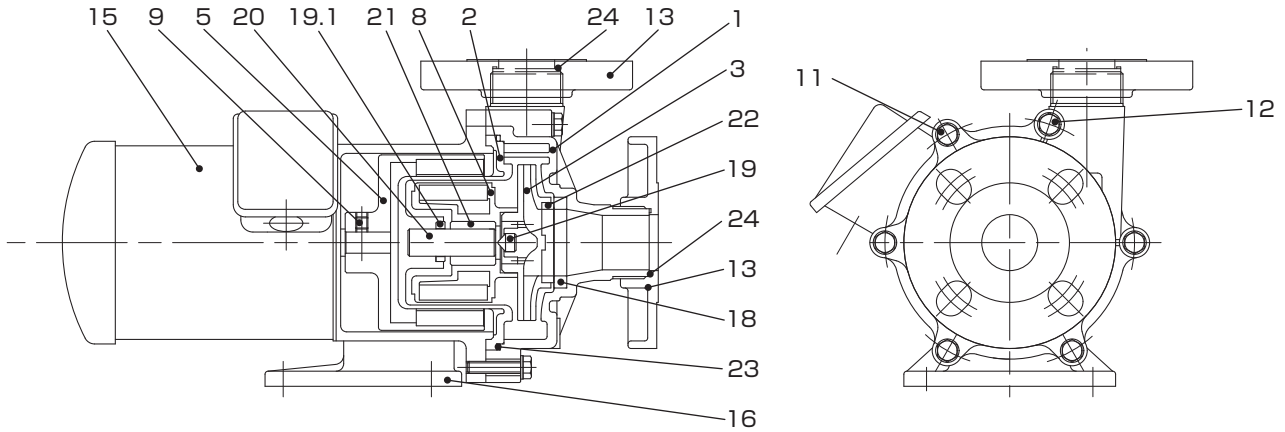

No.	Part names	Q'ty	Material	Remarks	
				MDH-F400	MDH-F401
1	Front casing	1	CFRETFE		
2	Rear casing	1	CFRETFE		
3	Impeller	1	CFRETFE		
5	Drive magnet unit	1	Ferrite mag.+aluminum alloy		
8	Magnet capsule	1	CFRETFE		
9	Hex socket set screw	2	Steel	M8 x 10	M8 x 10
11	Hex head bolt		Stainless steel	M8 x 35, with PW, SW (4)	M8 x 40, with PW, SW (6)
12	Hex head bolt		Stainless steel	M8 x 55, with PW, SW (2)	M8 x 65, with PW, SW (2)
13	Flange	2	GFRPP		
15	Motor	1			
16	Base	1	GFRPP		

No.	Part names	Q'ty	Material		Remarks	
			CFV-D	AAV-E	MDH-F400	MDH-F401
18	Liner ring	1	High purity alumina ceramics	Alumina ceramics		
19	Impeller thrust	1	High purity alumina ceramics			
19.1	Rear thrust	1	High purity alumina ceramics			
20	Spindle	1	High purity alumina ceramics	Alumina ceramics		
21	Bearing	1	High density carbon	Alumina ceramics		
22	Mouth ring	1	PTFE			
23	O ring	1	FKM		AS568-252	JIS B2401 G160
24	O ring	2	FKM		AS568-129	

NOTE: Actual dimensions may differ from the above information depending on model identification codes.

Outline

MDH-F422/-F423

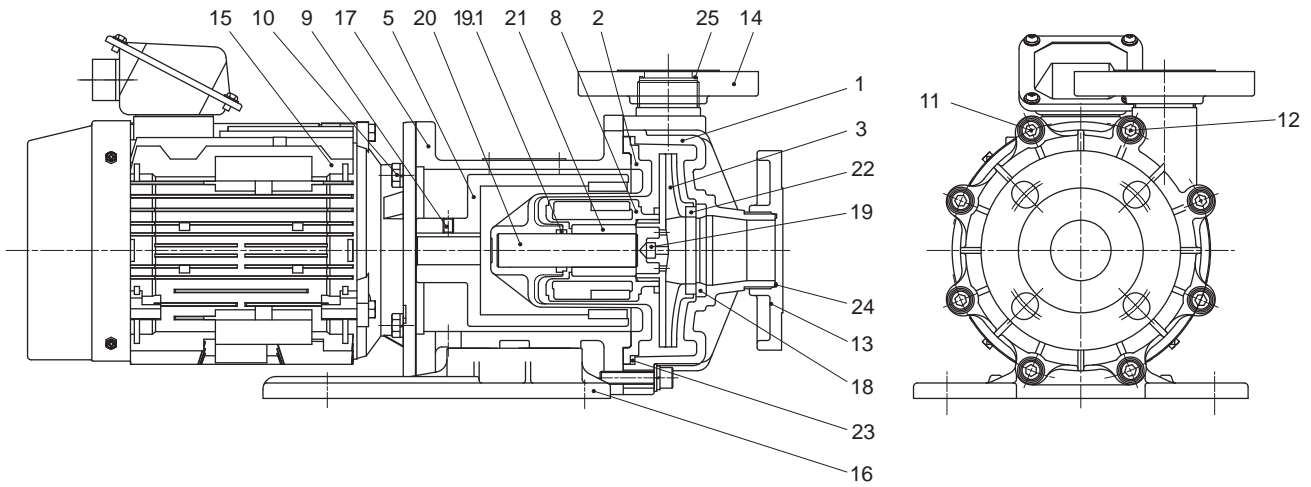

No.	Part names	Q'ty	Material	Remarks
1	Front casing	1	CFRETFE	
2	Rear casing	1	CFRETFE	
3	Impeller	1	CFRETFE	
5	Drive magnet unit	1	Rear earth magnet+FCD450	
8	Magnet capsule	1	CFRETFE	
9	Hex socket set screw	2	Steel	M8 x 10
10	Hex head bolt	4	Stainless steel	M10 x 30 with SW
11	Hex soch head bolt	6	Stainless steel	M10 x 45, with PW, SW
12	Hex soch head bolt	2	Stainless steel	M10 x 85, with PW, SW
13	Inlet flange	1	CFRETFE	
14	Outlet flange	1	CFRETFE	
15	Motor	1		
16	Base	1	MDH-F422/-F423: GFRPP	

No.	Part names	Q'ty	Material		Remarks
			CFV-D	AAV-E	
18	Liner ring	1	High purity alumina ceramics	Alumina ceramic	
19	Impeller thrust	1	High purity alumina ceramics		
19.1	Rear thrust	1	High purity alumina ceramics		
20	Spindle	1	High purity alumina ceramics		
21	Bearing	1	High density carbon	High purity alumina ceramics	
22	Mouth ring	1	PTFE		
23	O ring	1	FKM		JIS B2401 G165
24	O ring	1	FKM		AS568-136
25	O ring	1	FKM		AS568-129

Outline

7. Overview

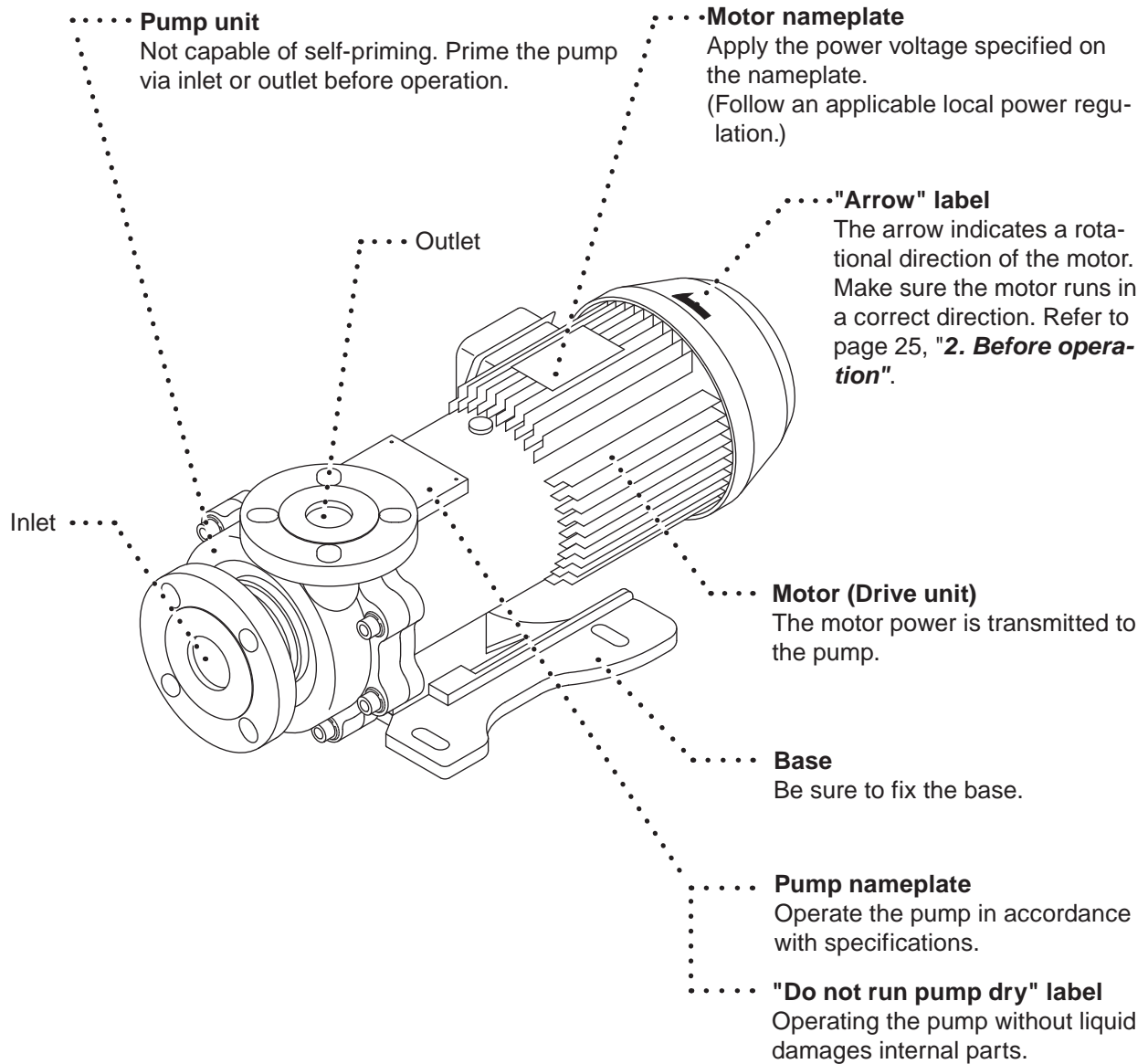

CAUTION

Wet a cloth with tap water and wring it out for cleaning the pump. Use a neutral detergent for greasy dirt and then rub with a dry cloth. Do not wipe nameplates, labels or pump body with any solvent.

Installation

<i>1. Before installation</i>	<i>14</i>
<i>2. Installation/ Pipework/ Wiring.....</i>	<i>17</i>

Installation

CAUTION

- **Do not run pump dry**

Do not run pump dry (operation without priming water or with a suction valve closed). Otherwise, internal parts are excessively worn by friction heat and fatal pump damage results.

*If the pump runs dry by mistake, turn off power and leave it for more than one hour to cool it down. Quick cooling can give rise to cracks on parts.

*An Iwaki dry run protector, the DR, is recommended for the prevention of dry running.



Prohibit

- **Do not bring the pump close to a flammable substance**

Keep the pump away from a flammable substance for the prevention of fire.



Prohibit

- **Do not remodel the pump**

A remodelled pump will not be warranted. Also, we are not responsible for personal injury or property damage due to any modification.



Prohibit

1. Before installation

Always observe the following points.

■ Dry-run-resistant models

Dry running for durations of one hour or less will not result in damage to dry-run-resistant pump models (model code ends with D). However, repeated dry runs of one hour or more and frequent dry running will result in friction between the sliding parts and faster wearing of the internal parts. As injecting liquid too soon after a dry run can give rise to cracks on parts as a result of rapid cooling, turn off power and do not operate the pump for at least 20 minutes after a dry run.

NOTE: Pumps with model codes that do not end with D cannot be run dry.

■ Precautions for starting/stopping the pump

(In case the pump is in flooded suction system.)

Follow the procedures below when starting/stopping the pump for the prevention of water hammer.

Take extra care when a discharge line is long.

When starting the pump

First, prime the pump. Then turn on power to start operation with a discharge valve fully closed.

And then gradually open the valve and adjust a flow rate to a specified point.

When stopping the pump

Gradually close a discharge valve. Turn off power and stop the pump after the valve is fully closed.

NOTE: Do not close a discharge valve sharply. Otherwise an excessive pressure may damage the pump, when using a solenoid valve, set it to close slowly.

Installation

■ Do not install or store the pump in the following places:

- Where ambient temperature exceeds 40 °C or falls below 0 °C.
- Where ambient humidity exceeds 85%RH or falls below 35%RH.
- Under a corrosive/explosive atmosphere (Except explosion-proof type).
- Where the pump is exposed to rain or liquid (Except outdoor-use type).
- Where the pump is subject to vibration or dust.

■ Always prime the pump

The MDH-F is not self-priming pump. Prime the pump every time the pump is operated. Do not run pump dry (operation without liquid.), or internal parts seizing or excessive wear results.

■ Maximum operating pressure

Do not allow a discharge pressure to exceed the limits below.

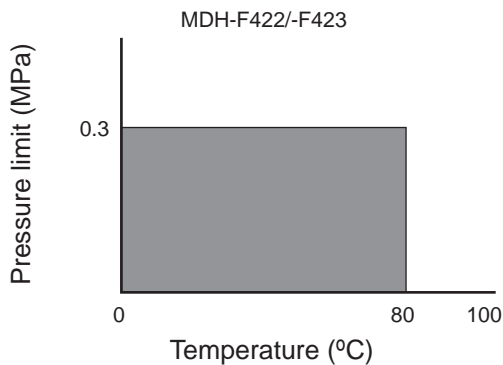
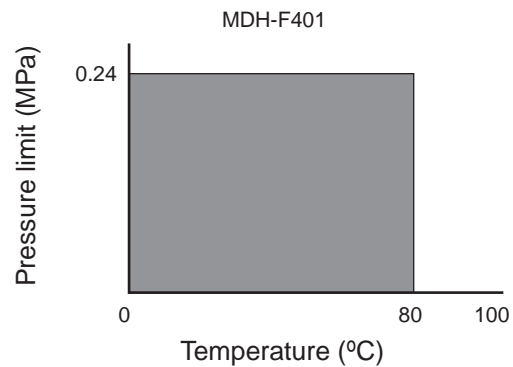
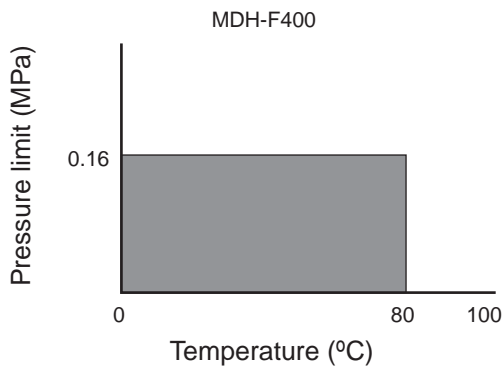

■ Liquid conditions

Slurry

The MDH-F series can not send slurry except the AAV type with an alumina ceramic bearing and an alumina ceramic spindle.

The AAV type can handle slurry up to 5% (concentration), 50µm (particle size) and 80Hs (hardness).

Contact us for details.

Performance change

Shaft power, discharge capacity and pump head varies depending on specific gravity and viscosity. The pump is designed for a specified liquid. If you made a change to the specified liquid, contact us.

Installation

Temperature change

Viscosity, vapour pressure and corrosive nature vary with liquid temperature. Always take account of temperature change.

▶ Allowable liquid temperature: 0-80°C (clean water)
▶ Allowable ambient temperature: 0-40°C
▶ Allowable ambient humidity: 35-85%RH

NOTE: Contact us for an allowable liquid temperature range at each liquid type.

■ Intermittent operation

Frequent ON-OFF operation damages the pump in a short time. Do not make ON-OFF operation more than six times per hour.

■ Disconnection of magnet coupling

Stop the pump immediately when the magnet coupling is disconnected. Otherwise magnetic force reduces.

■ Removing grease / AAV models (alumina ceramic bearing type)

The bearing is coated with fluoroplastic grease. Depending on the liquid pumped, elusion of the grease may occur. Contact us if intermixing of grease is not desirable.

■ Ascending area of a spike curve (in a performance curve)

When a specified point falls on an ascending area of a spike curve (generally, a flow is small in this area. See the standard performance curves), check and observe the following points.

- There should be no possibility of trapping air in a supply tank or a discharge line.
- A discharge valve should be installed near the pump outlet to adjust a flow rate.

Installation

2. Installation/ Pipework/ Wiring

Upon becoming aware of danger or abnormality during operation, terminate work immediately and inspect/solve problems.

WARNING

• Turn off power

Be sure to turn off power to stop the pump and related devices before work. Make sure no one turns on power by mistake while working on the pump, otherwise it may result in a serious accident. If your working area is noisy or dark, let other people know about the situation by displaying a notice such as "POWER OFF (Maintenance)" near a power switch.



Turning off power

• Do not lift the pump by gripping any plastic parts (pump unit, flange or base)

The pump can drop unintentionally as a plastic part breaks, resulting in serious injury.



• Electrical wiring

Electrical wiring and any work on power source must be performed by qualified persons only. We are not responsible for any injury and damage due to noncompliance with this notice.



Caution

■ Carrying in and out

When lifting up the pump, observe the following points.

- Secure the rope (chain) tightly around the pump, and lift the pump in its horizontal position.
- Be sure to use a strong rope (chain) that can support the weight of the pump.
- To avoid serious injury should the pump drop, do not stand beneath the pump during lifting.

When carrying in and out the pump, observe the following points.

- Do not lift the pump by holding plastic parts such as a pump unit, a flange or a base.
- Pump weight is about 43kg (the largest model). Work with sufficient number of people.
- Mount the pump horizontally on a pump base.

Installation

■ Installation

Arrange pump and pipework based on the following piping layout for a long period of operation.

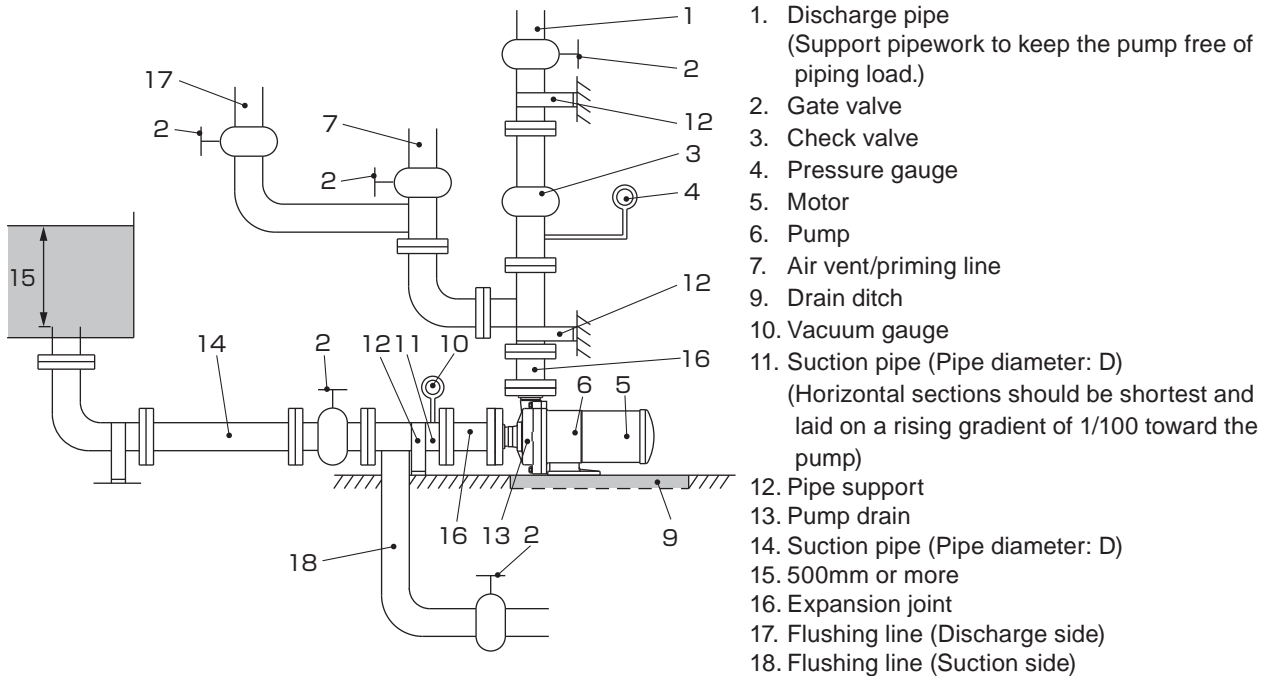

1. Discharge pipe
(Support pipework to keep the pump free of piping load.)
2. Gate valve
3. Check valve
4. Pressure gauge
5. Motor
6. Pump
7. Air vent/priming line
9. Drain ditch
10. Vacuum gauge
11. Suction pipe (Pipe diameter: D)
(Horizontal sections should be shortest and laid on a rising gradient of 1/100 toward the pump)
12. Pipe support
13. Pump drain
14. Suction pipe (Pipe diameter: D)
15. 500mm or more
16. Expansion joint
17. Flushing line (Discharge side)
18. Flushing line (Suction side)

Installation location

- Install the pump as close to a supply tank. Keep a liquid level in the tank higher than the pump at any time (flooded suction application).
- In case the pump is installed above a liquid level (suction lift application), lay on a priming line and mount a foot valve to the bottom of a suction line.

NOTE: The maximum suction lift varies with liquid characteristics, specific gravity, liquid temperature and suction line length. Contact us for detail.

Outdoor use motors (Indoor use motors can not be installed out of doors)

Outdoor use motors can also be used in doors. Protect the motor and electrical power distribution equipment from possible damage due to an accidental outflow or act of providence.

Installation space

- Select a flat and a rigid floor/foundation where is free from vibration and contortion.
- Keep a wide working area for convenience in installation and maintenance.

! CAUTION

Fix the pump firmly. Support piping so as not to directly weigh on the pump.

Installation

■ Foundation work

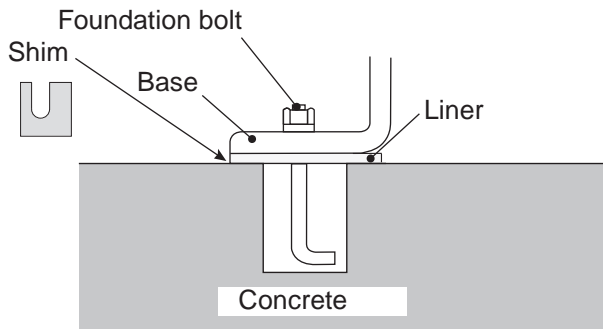

- Installation area should be larger than the footprint of the pump. Or a plastic base may break due to a concentrated load.
- If piping vibrates sympathetically with the pump in operation, provide an expansion joint between the pump and the piping to reduce vibration.

■ Tightening torque between the pump and pipework

Connect the pump to pipework via inlet and outlet flanges according to the tightening torque below. The table is based on use of metal pipe flanges with rubber gaskets. Tighten bolts diagonally at even torque.

Model	Bolt size	Tightening torque (N·m)
MDH-F400/-F401/-F422/-F423	M16	5

■ Piping load and momentum

Try not to apply a heavy load to the inlet and outlet flanges. Permissible piping weight and moment to the pump are as below.

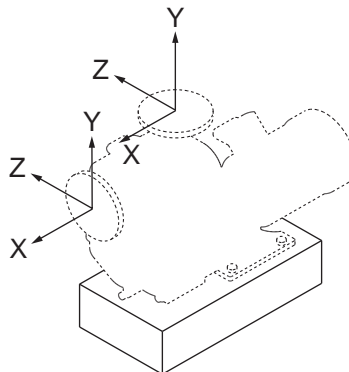

Installation

Permissible stress to outlet flange

	Pipe dia. (mm)
	40A
	Load
Load direction	kN
Fx	0.15
Fy: compression	0.20
Fy: tension	0.10
Fz	0.15

Permissible stress to inlet flange

	Pipe dia. (mm)
	40A, 50A
	Load
Load direction	kN
Fx	0.10
Fy	0.15
Fz	0.15

Permissible moment to outlet flange

	Pipe dia. (mm)
	40A
	Moment
Load direction	kN·m
Mx	0.05
My	0.10
Mz	0.10

Permissible moment to inlet flange

	Pipe dia. (mm)
	40A, 50A
	Moment
Load direction	kN·m
Mx	0.10
My	0.05
Mz	0.10

■ Suction line

1. Always build up a flooded suction system. Have a suction line shortest with the minimum number of bends. Support piping by pipe supports so that the pump is not subject to piping weight or thermal stress.
2. Make sure joints on a suction line are secure and air doesn't come in. If air is entrained into a suction line, liquid may not be pumped or the pump may break at its worst.
3. When the inner pressure of a supply tank is negative, or a suction lift or a suction line is long, apply the following formula.



$$NPSHa > NPSHr + 0.5\text{m}$$
 (See the standard performance curve for NPSHr.)
4. If a bent pipe is installed in a suction line, lay a straight line (length: 500mm or longer, or 8 times longer than the inlet I.D. of the pump) between a pump inlet and the bent pipe. Also, have the curvature radius of the bent pipe largest.
5. Do not allow any arched line where air may be trapped. A suction line should be laid on a rising gradient of 1/100 toward the pump.
6. If the inlet I.D. of the pump is different from that of a suction pipe, use an eccentric reducer pipe. Upper side should always be level. Air may be trapped if it is mounted upside down.

Installation

7. In flooded suction, install a gate valve on a suction line for easier overhaul & inspection. Keep this valve open at any time during operation.
8. Install a flushing line for cleaning the pump after handling a harmful liquid.
9. A suction pipe I.D. should be equal to or larger than a pump inlet I.D..

Suction lift application

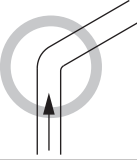
10. One end of a suction line should always be at least 500 mm lower than a liquid level in a supply tank for the prevention of air ingress.
11. Provide a screen in a supply tank for the prevention of foreign matter interfusion (Clean the screen periodically.). The distance between the end of a suction line and the bottom of a suction tank should be 1.5 times wider than a suction line I.D..
12. Be sure to install a foot valve at one end of a suction line.

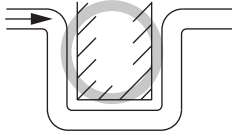
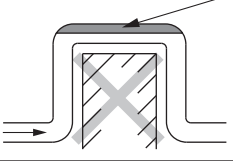
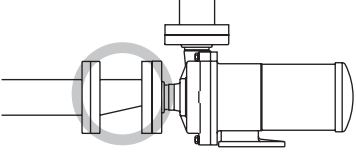
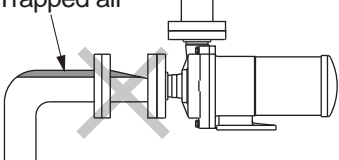
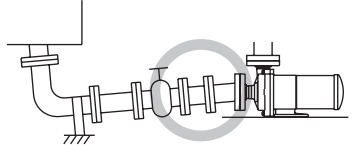
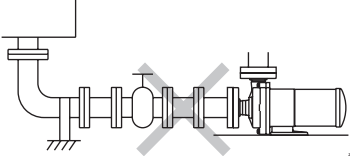
Good conditions	Unacceptable conditions
	
	
	
	

Installation

■ Discharge line

1. *Support discharge piping so as not to directly weigh on the pump.*
2. *Lay a priming line when the pump is not under a flooded suction system.*
3. *Pipe resistance rises too high to obtain an intended flow if a discharge pipe I.D. is too long. Always take account of the increment of pipe resistance.*
4. *Install a check valve in the following cases.*
When selecting a check valve, check its maximum operating pressure to make sure it tolerates a possible pressure rise due to water hammer or backflow.
 - A discharge line is too long.
 - Actual discharge head (static discharge head plus discharge pipe resistance) is more than 15m.
 - The end of a discharge line is 9m higher than a liquid level in a supply tank.
 - Several pumps are running in parallel.
5. *Install a gate valve on a discharge line to adjust a flow rate and to protect a motor from overload. If you are to install a check valve as necessary, it should be mounted in between the pump and the gate valve.*
6. *Install a pressure gauge on a discharge line.*
7. *Install an air vent line when a discharge line is laid long in a horizontal direction.*
8. *Drain*
Install a drain valve if it is possible for liquid in a discharge line to freeze.

■ Wiring

Electrical wiring and any work on power source must be performed by qualified persons only. We are not responsible for any injury and damage due to noncompliance with this notice. Contact us as necessary.

1. *Install an electromagnetic switch according to motor specifications (voltage, capacity, etc.).*
2. *Electromagnetic switches and push buttons should be installed away from the pump.*
3. *If the pump is used out of doors, protect switches from rainwater.*

Operation

1. Operational precautions	24
2. Before operation	25
3. Operation	25

Operation

1. Operational precautions

CAUTION

- Never run pump dry or shut off a suction valve during operation. Otherwise the pump fails in a short period.
- Check the rotational direction of the pump. Clockwise seen from the motor end is a correct direction. Operation in a reverse direction may cause pump damage.
- Stop the pump immediately when it is running under cavitation. Do not continue to run the pump when air is sucked from a suction line.
- Stop the pump immediately when the magnet coupling is disconnected. Magnetic force reduces if the pump keeps on running for more than one minute in this condition.
- Keep liquid temperature change within 80°C at any time during operation or stop.
- Start the pump with a discharge valve fully closed in order to avoid water hammer.
- Closed-discharge operation should be within one minute. If the pump runs with a discharge valve closed for a long time, the liquid temperature inside the pump rises and damages the pump.
- If power is interrupted while the pump is running, switch off the pump immediately and close a discharge valve.
- Take extra care for a discharge pressure not to exceed the pump limit. See page 15 for details.
- The surface temperature of the pump or pipe rises high along with liquid temperature in or right after operation. Take preventive measures.

Model	Liquid temperature	Surface temperature (at ambient 40°C)
MDH-F400/-F401/-F422/-F423	80°C	80°C

- Noise level

Model	MDH-F400	MDH-F401	MDH-F422/-F423
Noise level	70dB	75dB	75dB

In case the pump noise affects human health or communication to secure a safety, provide a noise reduction cover. Be careful not to reduce cooling effect by a motor fan.



Operation

2. Before operation

Take the next steps to start the pump at the first operation or after a long period of storage.

1. Clean the inside of piping and a supply tank.
2. Retighten flange fixing bolts and base fixing bolts.
3. Prime the pump and shut off a discharge valve. Check an air vent line and a flushing line are closed.
4. Run the motor for a moment (within a second) in order to check if the motor rotates to the direction pointed by an arrow label (clockwise seen from a motor fan). If the motor rotates in reverse, interchange two of three phase wires at random.

3. Operation

■ Starting process

Operate the pump by the following procedure.

	Operation procedure	Remarks
1	<ul style="list-style-type: none"> • Close or open valves. 	<ul style="list-style-type: none"> • Open suction valves fully. • Open discharge valves fully.
2	<ul style="list-style-type: none"> • Prime the pump. 	<ul style="list-style-type: none"> • Prime the pump unit and then close a discharge valve.
3	<ul style="list-style-type: none"> • Check the motor for correct rotating direction. Turn on power and then immediately (within one second) switch off the power. 	<ul style="list-style-type: none"> • Supply power to run the pump only for checking a rotational direction. (The correct direction is indicated with an arrow on the motor.) • Check if the motor fan smoothly stops after the power is turned off. <p>⚠ CAUTION</p> <ul style="list-style-type: none"> • The pump can be damaged when running in reverse rotation for a long time. • If the motor fan does not stop smoothly, the impeller may be loose. Check the inside of the pump.
4	<ul style="list-style-type: none"> • Turn on power and start the pump to adjust discharge pressure and capacity. Observe the minimum discharge capacity. See below. 	<ul style="list-style-type: none"> • Run the pump with a discharge valve closed. Once a pressure gauge points the max discharge pressure, open the discharge valve gradually to obtain a specified discharge pressure (or discharge capacity). <p>NOTE: Start to open/close a discharge valve gradually to adjust discharge pressure within one minute after the pump starts to run. Always check a discharge pressure gauge (or adjust discharge capacity by checking a flow meter).</p> <p>⚠ CAUTION</p> <p>Opening a valve sharply, the motor may be overloaded. Always open a valve while checking ammeters.</p> <p>Do not operate the pump below the minimum discharge capacity.</p> <p>▶The minimum discharge capacity: 10ℓ/min (MDH-F400/-F401), 20ℓ/min (MDH-F422/-F423)</p> <ul style="list-style-type: none"> • Observe the minimum discharge capacity for the prevention of continuous closed-discharge operation. This rule holds true to not only manual operation but also automatic operation. <p>⚠ CAUTION</p> <p>Do not run the pump longer than one minute with a discharge valve fully closed.</p>

Operation

	Operation procedure	Remarks
5	<p><Points to be checked> Check a flow meter and confirm that pump operation is as per specifications during operation.</p>	<ul style="list-style-type: none"> If a flow meter is not available, calculate a flow rate from discharge pressure, suction pressure and current value, taking account of pipe resistance.

CAUTION

In case of trouble, turn off power immediately and solve problems. See "*1. Troubleshooting*".

■ Stopping process

	Operation procedure	Remarks
1	<ul style="list-style-type: none"> Close a discharge valve gradually. 	<ul style="list-style-type: none"> Do not close a discharge valve sharply whether manually or automatically. Otherwise, the pump may be damaged by water hammer action which tends to occur with a long a discharge line. When using a solenoid valve, set it to close slowly.
2	<ul style="list-style-type: none"> Turn off power and stop pump operation. 	<ul style="list-style-type: none"> Check that the motor stops slowly and smoothly. If it does not stop smoothly, inspect the inside of the pump.
3	<p><Leaving the pump stop></p> <ul style="list-style-type: none"> Liquid in the pump may freeze and consequently damage the pump in winter. Drain liquid before storage. Be careful when draining harmful liquid. Use a heater to prevent liquid from freezing when the pump is temporarily stopped in an extremely cold region. In the event of a power failure, turn off power and close a discharge valve. 	

Maintenance

<i>1. Troubleshooting</i>	<i>28</i>
<i>2. Maintenance & Inspection.....</i>	<i>29</i>
<i>3. Spare & Wear parts</i>	<i>33</i>
<i>4. Dismantlement & Assembly.....</i>	<i>34</i>

Maintenance

1. Troubleshooting

If you can not find out the root cause of failure, contact us.

Troubles	Symptom		Cause	Point to be checked & Countermeasures
	When a discharge valve is closed.	When a discharge valve is opened.		
Liquid can not be discharged.		The readings of pressure/vacuum gauges drop to zero.	<ul style="list-style-type: none"> Priming liquid level is too low. Dry running 	<ul style="list-style-type: none"> Stop and prime the pump and resume operation.
	The pump can not be primed.		<ul style="list-style-type: none"> A foot valve doesn't close due to foreign matter clogging. 	<ul style="list-style-type: none"> Clean the foot valve and a seat.
	After starting, pressure drops sharply as a discharge valve is opened.	The readings of pressure/vacuum gauges fluctuate and drop to zero.	<ul style="list-style-type: none"> Air ingress through a suction line or a sealing surface. A disconnection of the magnet coupling 	<ul style="list-style-type: none"> Check if suction line connections are completely sealed. Check if liquid level in supply tank is not too low. Check amperage to see if the motor is not overloaded. Check if foreign matters do not lock the impeller or magnet capsule. Check if voltage is normal.
	Discharge pressure does not rise.		<ul style="list-style-type: none"> Low pump speed The pump rotates in reverse. 	<ul style="list-style-type: none"> Check wiring or motor. Correct wiring.
Discharge capacity is too low.	Pressure & vacuum are normal.	Vacuum is high.	<ul style="list-style-type: none"> The strainer is clogged with foreign matters. 	<ul style="list-style-type: none"> Remove foreign matters.
		Vacuum is very high.	<ul style="list-style-type: none"> Air pocket in suction line 	<ul style="list-style-type: none"> Check and correct suction line.
			<ul style="list-style-type: none"> Foreign matters are clogged at impeller inlet. 	<ul style="list-style-type: none"> Dismantle the section and remove foreign matters.
		The readings of pressure gauge & vacuum gauge fluctuate.	<ul style="list-style-type: none"> Air ingress from a suction line or a sealing surface. Discharge line clogs with foreign matters. 	<ul style="list-style-type: none"> Check suction line connections and retighten as necessary. Remove foreign matters or scale from pump/piping.
		Vacuum is high but pressure is normal.	<ul style="list-style-type: none"> Resistance such as air pocket in suction line. 	<ul style="list-style-type: none"> Check if there is no arched pipework.
		Vacuum is normal but pressure is high.	<ul style="list-style-type: none"> Actual head is too high or pipe resistance is too large. 	<ul style="list-style-type: none"> Check actual head and pipe resistance.
	Pressure is low and vacuum is very low.	Pressure and vacuum are low.	<ul style="list-style-type: none"> Motor rotates in reverse. 	<ul style="list-style-type: none"> Interchange motor wiring.
Motor is overheated.		<ul style="list-style-type: none"> Power voltage is low. Overload Ambient temperature is too high. 	<ul style="list-style-type: none"> Check voltage or frequency. Check specific gravity and viscosity of liquid. Keep good ventilation. 	
Discharge capacity is rapidly reduced.		Vacuum is high.	<ul style="list-style-type: none"> The strainer is clogged with foreign matters. 	<ul style="list-style-type: none"> Remove foreign matters.
Pump vibrates.			<ul style="list-style-type: none"> Poor foundation Loose mounting bolts. Cavitation occurs. Pump bearing is worn or melted. Magnet capsule or spindle is broken. Dynamic balance of drive magnet is upset. The rotating part hits against other parts. Motor bearing is worn. 	<ul style="list-style-type: none"> Reinstall the pump. Retighten the bolts. Remove the cause of cavitation. Replace as necessary. Replace as necessary. Remove the cause. Replace as necessary. Replace as necessary. Replace bearing or motor.

Maintenance

2. Maintenance & Inspection

WARNING

● **Wear protective clothing**

Coming in contact with a harmful chemical liquid may cause eye or skin trouble. Wear protective clothing such as a protective mask, goggles, gloves during work.



● **Turn off power**

Risk of electrical shock. Make sure a power source is turned off and the pump and devices are stopped prior to work.



■ **Daily inspection**

1. Always check for leakage before pump operation. Do not run the pump when liquid leaks.
2. Check whether the pump runs without abnormal noise or vibration.
3. Check a liquid level in a suction tank and a suction pressure.
4. Check that discharge capacity and a motor current value are as per specifications on the nameplate during operation.

NOTE: A discharge pressure is in proportion to the specific gravity of liquid. The cock of a pressure gauge or a vacuum gauge should be opened only when measurement is carried out. Close it right after measurement. If the cock remains open during pump operation, its meter mechanism may be adversely affected by the abnormal pressure rise caused by water hammer action.

5. If a spare pump is stored, run it from time to time to keep it ready for operation at any time when needed.
6. Check discharge pressure, discharge capacity, and motor power supply voltage to see if they do not fluctuate during pump operation. See "1. Troubleshooting" as necessary.

Maintenance

■ Periodic inspection

To ensure efficient and smooth operation, perform periodic inspection. Be careful not to damage internal sliding parts and plastic parts when dismantling the pump.

The magnetic force of a drive and a driven magnet is strong. Be careful not to catch the finger. Do not put electrical devices such as a watch and a mag card close to those magnets.

Interval	Part names	Inspection items	Measures
Every six months (Maintain an inspection record)	(Drive magnet unit) Drive magnet Hex socket set screw	<ul style="list-style-type: none"> ● Wear trace ● If the drive magnet is correctly mounted by hex socket set screws and they are not loose. ● Decentering of magnet and motor shaft (Max. 1/10mm) 	<ul style="list-style-type: none"> ○ Finding wear trace, contact us. ○ Reset the drive magnet to the motor shaft and retighten the screws. ○ Retighten the hex socket set screws or replace the drive magnet (Contact us).
	Rear casing Rear thrust	<ul style="list-style-type: none"> ● Wear tracks on an inner surface ● Cracks ● Wear of the thrust ring ● Wear of the spindle tip ● Contamination in rear casing 	<ul style="list-style-type: none"> ○ Contact us. ○ Replace as necessary. ○ Contact us. ○ Replace as necessary. ○ Remove contamination.
	(Magnet capsule unit) Magnet capsule Bearing	<ul style="list-style-type: none"> ● Wear tracks on the rear end or side face of the magnet capsule ● Cracks on the rear end or side face of the magnet capsule ● Wear of the bearing ● Loose fit of the impeller unit 	<ul style="list-style-type: none"> ○ Contact us. ○ Contact us. ○ Replace as necessary. ○ Replace or contact us.
	(Impeller unit) Impeller Mouth ring	<ul style="list-style-type: none"> ● Wear of the mouth ring ● Wear of the Impeller thrust ● Cracks ● Contamination in the impeller ● Impeller deformation 	<ul style="list-style-type: none"> ○ Replace as necessary. ○ Replace as necessary. ○ Replace as necessary. ○ Remove contamination. ○ Replace as necessary.
	Front casing Rear casing Liner ring	<ul style="list-style-type: none"> ● Contamination ● Cracks ● Wear, cracks and wear tracks on a liner ring ● Swelling or a crack on O ring ● Wear tracks on an unlikely portion 	<ul style="list-style-type: none"> ○ Remove contamination. ○ Replace as necessary. ○ Contact us. ○ Replace as necessary. ○ Contact us.
	Spindle	<ul style="list-style-type: none"> ● Cracks ● Wear degree 	<ul style="list-style-type: none"> ○ Replace as necessary. ○ Replace as necessary.

Maintenance

■ Wear limits of bearing and spindle

Check wear degree of the bearing and spindle.

Unit: mm

Model	MDH-F400		MDH-F401/-F422/-F423	
	Before use	Wear limit	Before use	Wear limit
Bearing inner diameter	18	19	26	27
Spindle outer diameter	18	17	26	25

1. Above values show wear limit of the bearing and spindle.
2. If the clearance between the bearing and the spindle exceeds 1 mm, either of them, whichever has greater wear, should be replaced regardless of the wear limit. For AAV type, replace the bearing and spindle at the same time.
3. The spindle cannot be replaced on its own, as it is part of the rear casing. When the spindle requires replacement, replace the entire rear casing.
4. Sliding parts may suffer initial wear in an initial operation phase but this is not abnormal.

■ Wear limit of mouth ring

Check wear degree of the mouth ring.

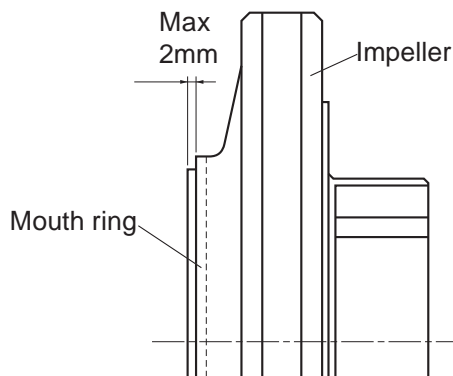

Model	Mouth ring thickness	
	Initial thickness	Wear limit
MDH-F400/-F401/ -F422/-F423	8mm	6mm

NOTE: The mouth ring is 2 mm forward from the impeller when shipped. Before the step has reduced to 0 mm, replace the impeller unit.

■ Wear limits of impeller thrust and spindle tip

The impeller thrust and spindle tip of the MDH-F pump come into contact with each other during abnormal operations (cavitation, dry running, etc.). As excessive wear to the impeller thrust and spindle tip will result in pump malfunctions, check the sliding condition of the impeller thrust and spindle in the following situations.

- **For dry-run-resistant pumps (model code ends with D)**

If abnormal operations such as dry running and cavitation were performed for 3 hours total or more.

- **For dry-run-prohibited pumps (model code ends with E)**

If abnormal operations such as dry running and cavitation were performed accidentally, even for short periods.

Maintenance

■ Checking procedure

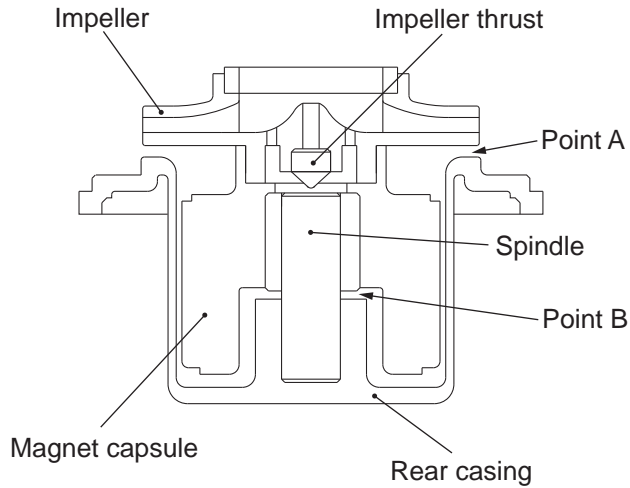

1. Remove the rear casing from the motor bracket, and insert the magnet capsule to which the impeller is mounted into the rear casing.
2. Orient the parts so that the impeller is on top, and gently turn the impeller by hand.
 - **Wear limit not reached**
The impeller and magnet capsule turn easily and smoothly.
 - **Wear limit reached**
The impeller and magnet capsule do not turn smoothly. When the impeller thrust and spindle tip have reached their wear limits, contact occurs at points A and B shown at the left, preventing smooth turning. Replace the impeller and rear casing with new parts in such cases.

Maintenance

3. Spare & Wear parts

Appropriate spare parts are necessary for a long period of continuous operation. We recommend that wear parts be always in stock. Place an order for spares with the following information.

1. Part names and part number (See the diagram below.)
2. Pump model identification code and manufacturing number (See pump nameplate.)
3. Drawing number if you have our approval drawing

■ MDH-F400/-F401 Spare parts list

No.	Part names	Material	MDH-F400	MDH-F401	
1	Front casing unit	AAV	CFRETFE	MHF0001	MHF0038
		CFV	CFRETFE	MHF0002	MHF0039
13	Flange	CFRETFE	MHF0003		
24	O ring (for flange)	FKM	MHF0004		
23	O ring (for casing)	FKM	MHF0007	MHF0044	
8+21	Magnet capsule unit	AAV	CFRETFE, Ceramic	MHF0938	MHF0061
		CFV	CFRETFE, High density carbon	MHF0937	MHF0062
2+19.1+20	Rear casing unit	AAV	CFRETFE	MHF0855	MHF0870
		CFV	CFRETFE	MHF0856	MHF0871
3+19+22	Impeller unit 50Hz	T	CFRETFE	MHF0849	MHF0864
		V	CFRETFE	MHF0850	MHF0865
		W	CFRETFE	MHF0851	MHF0866
	Impeller unit 60Hz	X	CFRETFE	MHF0852	MHF0867
		Y	CFRETFE	MHF0853	MHF0868
		Z	CFRETFE	MHF0854	MHF0869

■ MDH-F422/-F423 Spare parts list

No.	Part names	Material	MDH-F422	MDH-F423	
1	Front casing unit	AAV	CFRETFE	MHF0979	
		CFV	CFRETFE	MHF0980	
13	Inlet flange	CFRETFE	MHF0077		
14	Outlet flange	CFRETFE	MHF0078		
24	O ring (for flange)	FKM	MHF0079		
		EPDM	-		
25	O ring (for flange)	FKM	MHF0004		
		EPDM	-		
23	O ring (for casing)	FKM	MHF0081		
		EPDM	-		
2+19.1+20	Rear casing unit	CFRETFE	MHF0981		
8+21	Magnet capsule unit	AAV	CFRETFE, Ceramic	MHF0989	
		CFV	CFRETFE, High density carbon	MHF0990	
3+19+22	Impeller unit 50Hz	T	CFRETFE	MHF1016	MHF1023
		V	CFRETFE	MHF1017	MHF1024
		W	CFRETFE	MHF1018	MHF1025
	Impeller unit 60Hz	X	CFRETFE	MHF1019	
		Y	CFRETFE	MHF1020	MHF1026
		Z	CFRETFE	MHF1021	MHF1027

Maintenance

4. Dismantlement & Assembly

WARNING

- **Wear protective clothing**

Coming in contact with a harmful chemical liquid may cause eye or skin trouble. Wear protective clothing such as a protective mask, goggles, gloves during work.



- **Turn off power**

Risk of electrical shock. Make sure a power source is turned off and the pump and devices are stopped prior to work.



- ▶ Mark each wire so that the wires can be connected correctly to the motor.
- ▶ Do not disassemble the pump beyond the extent shown on this manual.
- ▶ Make sure to close suction and discharge valves before dismantling/assembling the pump. Clean the inside of the pump as well.
- ▶ Magnetic force of the pump is strong. Be careful not to catch the finger in parts. Do not allow iron pieces or powders to stick to a drive and a driven magnet.
- ▶ A pair of strong magnets is mounted in the pump and its magnetic force may affect magnetic disks/cards or wrist watches. Do not bring them close to the pump.

Maintenance

■ Dismantlement

1. Remove hex head bolts (MDH-F400/-F401) or hex socket head bolts from the front casing and remove it from a motor bracket. At this time drain and collect residual liquid and decontaminate wet ends.
2. Pull out the combination of an impeller unit and a magnet capsule unit. Be careful not to catch the finger in the impeller unit and the bracket.
3. Detach the impeller unit from the magnet capsule unit as necessary. Be careful not to damage the units.

a. MDH-F400/-F401

Slightly tap the back of the impeller unit by a plastic hammer while holding the magnet capsule unit. If it is hard to remove, warm them in hot water (approx. 90°C) for 5 minutes.

Be careful not to get scalded with hot water.

b. MDH-F422/-F423

The impeller is attached to the magnet capsule by a screw joint. To dismantle, hold the magnet capsule with the impeller facing forward, and loosen the joint by turning it anticlockwise. If you have difficulty loosening the screw joint, warm the impeller and magnet capsule in hot water (approx. 90°C) for 5 minutes, and then try loosening again. Be careful not to scald in hot water.

4. Slide a top of a flathead screw driver in between the rear casing and the motor bracket to pull out the casing. Pay attention not to scratch an O ring surface.

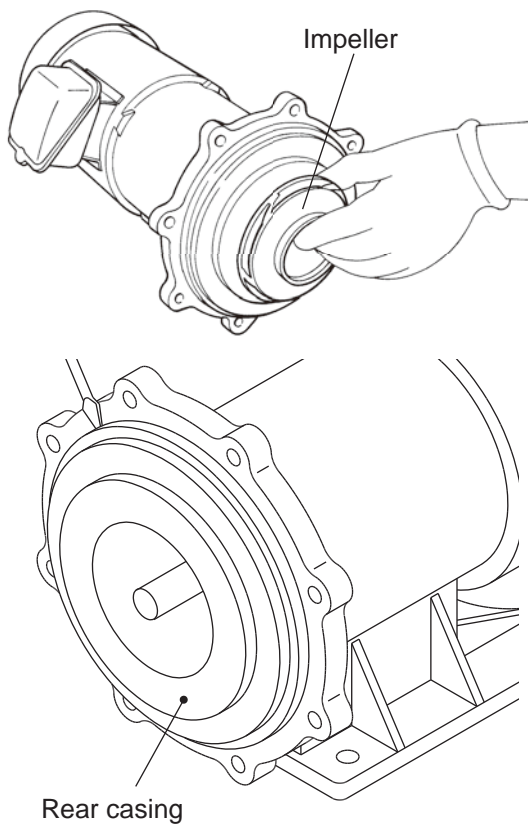

Maintenance

■ Assembly

1. Mount the impeller unit to the magnet capsule unit.

a. MDH-F400/-F401

Align the indentations in the magnet capsule and the impeller, and slide the impeller into the magnet capsule as far as it will go.

b. MDH-F422/-F423

Secure the impeller to the magnet capsule by turning it in the opposite direction from when you detached it. Make sure to secure the screw joint tightly.

If you have difficulty fitting the parts or turning the screw joint, warm only the magnet capsule in hot water (approx. 90°C) for 5 minutes, and then try attaching again. Be careful not to scald at this time.

2. Insert the combination of the impeller unit and the magnet capsule unit into the rear casing slowly.

Do not allow foreign matters such as iron pieces to adhere to the magnet capsule unit.

3. Mount the rear casing with the combined units in it to the bracket.

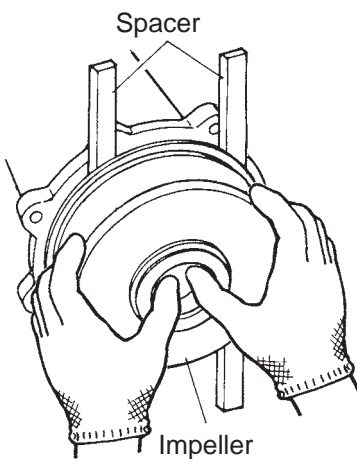

⚠ CAUTION

Magnet force is very powerful. Place plastic or wooden spacers so as not to catch the fingers.

4. Fit an O ring to the rear casing. Check that sealing surfaces are free of dust or scratches. Make sure that an O ring is in place and will not be out of a groove.

5. Fasten the front casing to the motor bracket.

Tighten the hex socket bolts evenly. Tightening torque is shown below.

Model	Tightening torque
MDH-F400/-F401	11.8N•m
MDH-F422/-F423	14.7N•m





<http://www.iwakipumps.jp>
IWAKI CO.,LTD. 6-6 Kanda-Sudacho 2-chome Chiyoda-ku Tokyo 101-8558 Japan
TEL: +81 3 3254 2935 FAX: +81 3 3252 8892

European office / IWAKI Europe GmbH
TEL: +49 2154 9254 0 FAX: +49 2154 9254 48

Germany / IWAKI Europe GmbH
TEL: +49 2154 9254 50 FAX: +49 2154 9254 55

Holland / IWAKI Europe GmbH (Netherlands Branch)
TEL: +31 74 2420011 FAX: +49 2154 9254 48

Italy / IWAKI Europe GmbH (Italy Branch)
TEL: +39 0444 371115 FAX: +39 0444 335350

Spain / IWAKI Europe GmbH (Spain Branch)
TEL: +34 93 37 70 198 FAX: +34 93 47 40 991

Belgium / IWAKI Belgium N.V.
TEL: +32 13 670200 FAX: +32 13 672030

Denmark / IWAKI Nordic A/S
TEL: +45 48 242345 FAX: +45 48 242346

Finland / IWAKI Suomi Oy
TEL: +358 9 2745810 FAX: +358 9 2742715

France / IWAKI France S.A.
TEL: +33 1 69 63 33 70 FAX: +33 1 64 49 92 73

Norway / IWAKI Norge AS
TEL: +47 23 38 49 00 FAX: +47 23 38 49 01

Sweden / IWAKI Sverige AB
TEL: +46 8 511 72900 FAX: +46 8 511 72922

U.K. / IWAKI Pumps (U.K.) LTD.
TEL: +44 1743 231363 FAX: +44 1743 366507

U.S.A. / IWAKI America Inc.
TEL: +1 508 429 1440 FAX: +1 508 429 1386

Argentina / IWAKI America Inc. (Argentina Branch)
TEL: +54 11 4745 4116

Singapore / IWAKI Singapore Pte Ltd.
TEL: +65 6316 2028 FAX: +65 6316 3221

Indonesia / IWAKI Singapore (Indonesia Branch)
TEL: +62 21 6906606 FAX: +62 21 6906612

Malaysia / IWAKIIm SDN. BHD.
TEL: +60 3 7803 8807 FAX: +60 3 7803 4800

Australia / IWAKI Pumps Australia Pty Ltd.
TEL: +61 2 9899 2411 FAX: +61 2 9899 2421

China (Hong Kong) / IWAKI Pumps Co., Ltd.
TEL: +852 2607 1168 FAX: +852 2607 1000

China (Guangzhou) / GFTZ IWAKI Engineering & Trading Co., Ltd.
TEL: +86 20 84350603 FAX: +86 20 84359181

China / IWAKI Pumps (Shanghai) Co., Ltd.
TEL: +86 21 6272 7502 FAX: +86 21 6272 6929

Korea / IWAKI Korea Co., Ltd.
TEL: +82 2 2630 4800 FAX: +82 2 2630 4801

Taiwan / IWAKI Pumps Taiwan Co., Ltd.
TEL: +886 2 8227 6900 FAX: +886 2 8227 6818

Thailand / IWAKI (Thailand) Co., Ltd.
TEL: +66 2 322 2471 FAX: +66 2 322 2477

Vietnam / IWAKI Pumps Vietnam Co., Ltd.
TEL: +84 613 933456 FAX: +84 613 933399