

# **IWAKI Magnetic Drive Pump**

---

**MD-55F/-100F type**

---

**Instruction Manual**

---

 Read this manual before use of product

Thank you for selecting an Iwaki MD-55F/-100F type Magnetic Drive Pump. This instruction manual deals with "*Safety Instructions*", "*Outline*", "*Installation*", "*Operation*" and "*Maintenance*" sections.

Please read through this instruction manual to ensure the optimum performance, safety and service of your pump.

## Contents

<b>Safety Instructions</b> .....	<b>1</b>
<i>Outline</i>	
1. Unpacking & Inspection .....	3
2. Operating principle .....	3
3. Identification code .....	4
4. Specification .....	4
5. Outer dimensions .....	5
6. Performance curves .....	5
7. Overview & Label .....	6
8. Part names & Structure .....	7
<i>Installation</i>	
1. Before installation .....	8
2. Installation/Piping/Electrical wiring .....	10
<i>Operation</i>	
1. Before operation .....	15
2. Operation .....	15
<i>Maintenance</i>	
1. Troubleshooting .....	18
2. Maintenance & Inspection .....	18
3. Drainage .....	20



*This instruction manual should be kept on hand by the end user for quick reference.*

*Contact us or your nearest dealer if you have any questions.*



## Important Instruction

### For the Safe and Correct Handling of the Pump

- "Safety Instruction" section deals with important details about handling of the product. Before use, read this section carefully for the prevention of personnel injury or property damage.
- Observe the instructions accompanied with "WARNING" or "CAUTION" in this manual. These instructions are very important for protecting pump users from dangerous situations.
- The symbols on this instruction manual have the following meanings:

 <b>WARNING</b>	<b>Nonobservance or misapplication of the contents of "Warning" section could lead to a serious accident which may result in death.</b>
 <b>CAUTION</b>	<b>Nonobservance or misapplication of the contents of "Caution" section could lead to personal injury or property damage.</b>

### Types of Symbols

	Indicates a prohibited action or procedure. Inside or near this circle, a concrete and practical image of the activity to be avoided is depicted.
	Indicates an important action or procedure which must be performed or carried out without fail. Failure to follow the instructions herein can lead to malfunction or damage to the pump.

### Export Restrictions

Technical information contained in this instruction manual might be treated as controlled technology in your countries, due to agreements in international regime for export control.

Please be reminded that export license/permission could be required when this manual is provided, due to export control regulations of your country.

# Safety Instructions

## WARNING

- **Turn off power.**

Risk of electrical shock. Dismantling/assembling the pump unit without turning off power may cause an electrical shock. Before engaging in any maintenance or inspection work, be sure to turn off the pump and related devices.



Power off

- **Terminate operation.**

On sensing any abnormality, stop operation immediately and inspect/solve problems.



- **For specified application only**

The use of the pump in any application other than those clearly specified may result in injury or damage. Use the pump in a specified condition.



Prohibited

- **No dismantlement/modification**

Do not dismantle/modify the pump. We are not responsible for any accidents or damage due to modification.



No modification  
No dismantlement

- **Wear protective clothing.**

Always wear protective clothing such as safety goggles and protective gloves during pipework or dismantlement.



Wear protectors

## CAUTION

- **Restriction on operator**

The pump should be handled by a qualified person with a full understanding.



Prohibited

- **Specified power only**

Do not apply any power other than the specified one on the nameplate. Otherwise damage or fire may result.



Prohibited

- **Do not wet the pump.**

If a liquid spills over electric parts or wires, a fire or electrical shock may result. Install the pump in a place free from liquid spillage.



Prohibited

- **Ventilation**

Poisoning may result when handling a toxic or odorous liquid. Keep good ventilation in a work area.



Caution

- **Countermeasure against efflux**

Take protective measures against the accidental efflux caused by pump or pipe breakage.



Caution

- **Damaged pumps**

Do not use any damaged pump. Using a damaged pump may lead to an electric leak or shock.



Prohibited

# Safety Instructions

## CAUTION

- **Do not place the pump close to water.**

The pump is not dust-/water-proof construction. The use of the pump in a humid place or a place where the pump can get wet may result in an electrical shock or short-circuit.



Prohibited

- **Do not run pump dry.**

If the pump runs without a liquid, the pump is damaged by friction heat.



Prohibited

- **Do not damage a power cable.**

Risk of fire or electrical shock. Do not scratch, modify, or pull a power cable. The cable can also be damaged when it is heated or loaded with a heavy thing.



Caution

- **Earthing**

Risk of electrical shock. Always earth the pump.



Earthing

- **Do not pressurize the pump over the maximum discharge pressure.**

A leak may result from the sealing surface of O ring, or the pump fails at worst.



Prohibited

- **Install an earth leakage breaker.**

An electrical failure of the pump may adversely affect related devices. Purchase and install an earth leakage breaker separately.



Electrical shock

## CAUTION

- **Power cable is not replaceable.**

Do not use any damaged power cable for the prevention of a fire or electrical shock. The cable is not replaceable, so that the whole pump unit needs to be replaced when the cable is damaged.



Electrical shock

- **Limited operating site and storage**

Do not install or store the pump:

1. Where ambient temperature can exceed 40°C or falls below 0°C.
2. Under a flammable/corrosive atmosphere.
3. Under direct sunlight or rainwater



Prohibited

- **Disposal of the used pump**

Dispose of any used or damaged pump in accordance with relevant regulations. Consult a licensed industrial waste products disposing company.



- **Static electricity**

When low electric conductivity liquids such as ultra-pure water and fluor inactive liquid (e.g. Fluorinert™) are handled, static electricity may generate in the pump and may cause static discharge. Take countermeasures to remove static electricity.



- **Fasten the front casing tight**

Liquid may leak if front casing fixing screws are loose. Tighten the screws before initial operation or at intervals.



Caution

# Outline

Before use, check the specification, limitation and hazardous nature of the pump.

## 1. Unpacking & Inspection

On unpacking the product, check the following points. If you find any problems, contact your nearest distributor.

1. Check the information on the nameplate such as model, discharge capacity, discharge head and voltage to see that the product is delivered as per order.

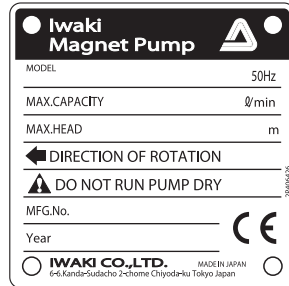

2. Check for transit damage, deformation, and loose bolts.

## 2. Operating principle

The MD-F is a compact magnetic drive centrifugal pump with fluoroplastic and fine ceramic wet ends and is capable of handling a strong acid and alkali.

The magnetic force between drive and driven magnets rotates the impeller in the pump chamber, where a liquid is transferred from the inlet to outlet.

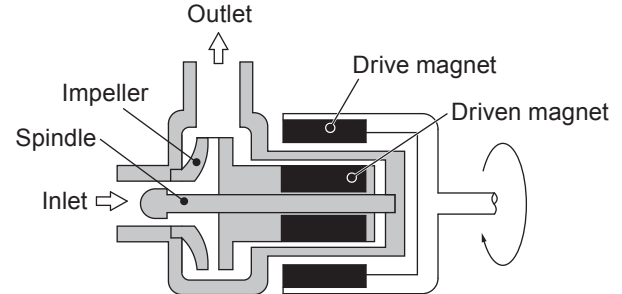

# Outline

## 3. Identification code

MD-55F/-100F

**MD - 55 F G X K - 01**  
 a      b      a      c      d      e      f

- a. Series model  
CFRETFE casing material
- b. Pump size (motor output)  
55(90W)/ 100(260W)
- c. Connection  
No code : R thread
- d. Impeller type  
X : Low viscosity  
Y : Medium viscosity
- e. Purpose  
No code : Standard  
K : Gold coating
- f. Special version  
No code : Standard  
01-99 : Special design

## 4. Specification

50Hz

Model	Impeller type	Connection size	Max flow (L/min)	Max head (m)	Norm flow	Max SG	Motor		Mass (kg)
							Rated output (W)	Power	
MD-55FX	X	R1	65	7.8	5.4m-30L/min	1.3	90	1-phase 100V/ 1-phase 200V	5.4
MD-55FY	Y		60	5.4	3.8m-30L/min	2.0			
MD-100FX	X	R1	125	10.5	7.5m-65L/min	1.2	260	1-phase 100V/ 3-phase 200V	8.5
MD-100FY	Y		115	8.5	6m-60L/min	2.0			

NOTE:

- a. Performance data is based on pumping of clear water at ambient temperature.
- b. The maximum flow is obtained at zero discharge head, and the maximum head is obtained at the maximum pressure.
- c. The maximum specific gravity is obtained at or near the maximum flow. Note that the limitation varies with a duty point, ambient/ liquid temperature or liquid viscosity.
- d. The maximum viscosity at SG.1.0 is up to 30mPa\*s for all the models.
- e. Allowable liquid temperature range is 0-80°C.  
\*Note that the liquid temperature range is based on pumping clean water and it changes with liquid property and operating conditions. Frozen liquid can not be transferred.
- f. All the single-phase motors used for the MD-55F/-100F series are capacitor-run induction motor.
- g. See the specification label for information other than that articulated above.

# Outline

## 5. Outer dimensions

MD-55F

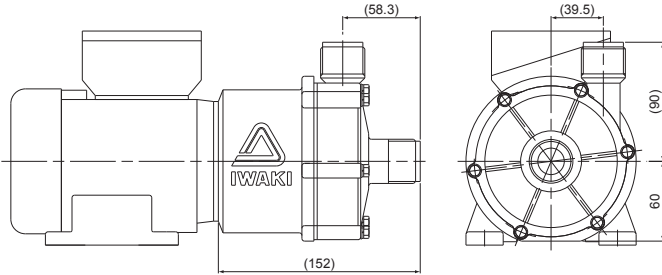

MD-100F

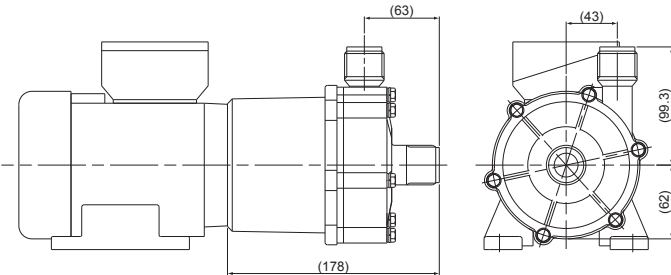

## 6. Performance curves

MD-55F/-100F

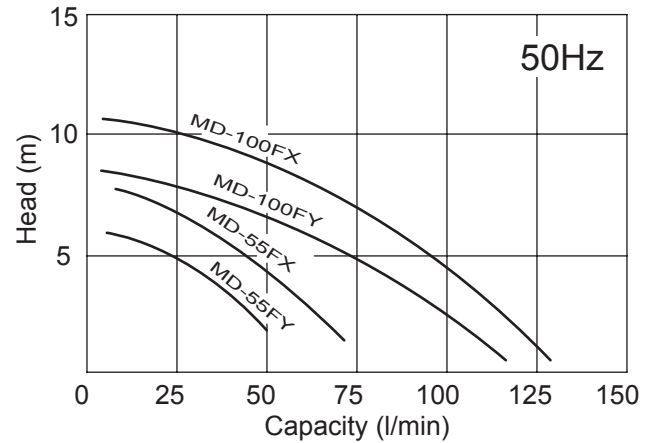

NOTE: This performance curve is collected when pumping clear water at ambient temperature under a flooded suction system.

## 7. Overview & Label

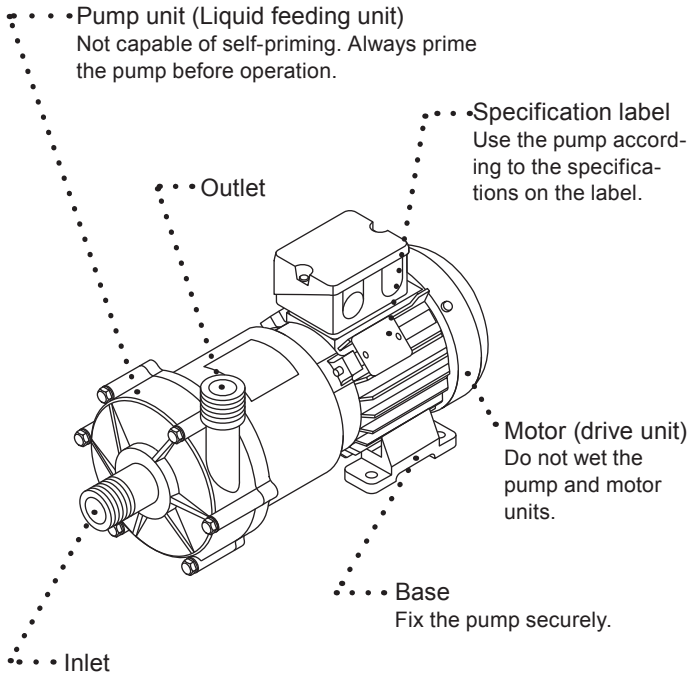



# Outline

## 8. Part names & Structure

MD-55F

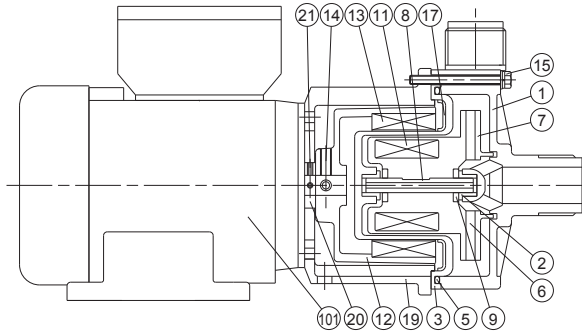

No.	Part names	Q'ty	Materials	
			MD-55F	MD-100F
1	Front casing	1	CFRETFE	
2	Bearing	2	SiC	
3	Rear casing	1	CFRETFE	
5	O ring	1	FKM-A	
6	Impeller	1	CFRETFE	
7	Shroud	1	CFRETFE	
8	Spindle	1	SiC	
9	Thrust ring	2	SiC	
11	Driven magnet	1	FERRITE	

MD-100F

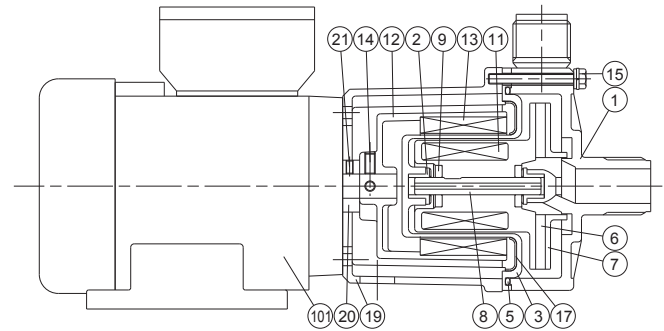

No.	Part names	Q'ty	Materials	
			MD-55F	MD-100F
12	Magnet housing	1	Aluminium alloy	
13	Drive magnet	1	FERRITE	
14	Hex socket set screw	2	Steel	
15	Hex head bolt	6	Stainless steel	
17	Retainer ring	1	SUS304	
19	Bracket	1	FC200	
20	Spacer	1	Aluminium	
21	Hex socket set screw	1(2)*	Steel	
101	Motor	1	-	

\*The MD-100F has two hexagon socket set screws.

# Installation

## 1. Before Installation

Read through this instruction manual before use. Carry out installation work with a full understanding.

### WARNING

- Risk of electrical shock. Dismantling/assembling the pump unit without turning off power may cause an electrical shock. Before engaging in any maintenance or inspection work, be sure to turn off the pump and related devices.
- Electrical work or wiring must be carried out by a qualified person according to local laws or regulations.

### CAUTION

- Do not drop the pump or subject it to strong impact during installation or transport.
- A strong magnet is inside the pump. Do not bring a watch or floppy disk which may be adversely affected by a magnetic force.

- Dropping or subjecting the pump to strong impact, failure may result. Handle the pump with care.



- The pump is not capable of self-priming. Always prime the pump before operation.

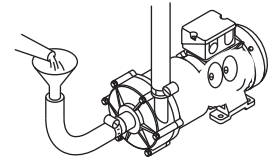

- The motor is not water-/dust-proof. Do not wet the motor, or it may fail.

- The pump doesn't have an ON-OFF switch. The pump starts as a power cable is plugged in.

# Installation

---

- Banned solutions
  - Halogenated hydrocarbons such as trichloroethylene and carbon tetrachloride
  - Ether and low-grade ester
  - Slurry (Never use slurry, which wears out the pump bearings.)
- A strong magnet is inside the pump. Do not use the pump with any liquid which contains metals such as iron and nickel.
- Do not pull or knot a power cable or place a heavy stuff on it. Damage to a power cable could lead to a fire or electrical shock.
- Do not use any damaged pump. Using a damaged pump may lead to an electric leak or shock.

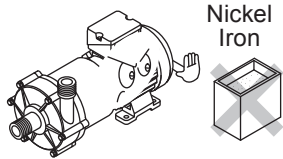

## ⚠ CAUTION

**Do not install or store the pump in the following places:**

- 1. Where ambient temperature exceeds 40°C or falls below 0°C.**
- 2. In a dusty/humid place.**
- 3. Under direct sunlight or wind & rain.**

- Install the pump as close to a supply tank. Keep a liquid level in the tank higher than the pump at any time.
- An electrical failure of the pump may result in electric shock. Purchase and install an earth leakage breaker separately.

# Installation

## 2. Installation/ Piping/ Electrical wiring

*Stop working upon sensing danger or abnormality.*

### 2.1 Installation

#### 1. Installation location

Select a convenient place for maintenance and inspection. Observe the allowable room temperature range of 0-40°C and the allowable maximum ambient humidity of 90%RH. Ensure proper ventilation at the operation site. Install the pump where it can be kept dry.

#### 2. Mounting position

This pump is not capable of self-priming. Flooded suction application is ideal. The pump should be installed 30cm lower than a suction liquid level, or a bearing may be worn soon by entrained air.

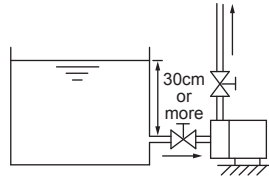

#### 3. Outlet direction

Always direct the outlet upward or entrained air can not be expelled.

Direct the outlet upward

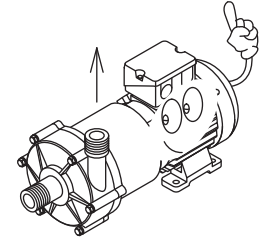

#### 4. Do not mount the pump vertically.

#### 5. Pump fixation

Secure the pump by fixing its base on a flat and a stable foundation.

NOTE: Use corrosive resistant fixing screws.

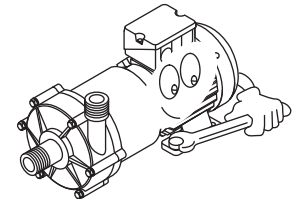

# Installation

## 2.2 Piping

### ■ Before tubing

- Using a high flow pump and a small supply tank, a liquid level in the tank changes greatly.
- Do not allow a drop of adhesive agent or sealant into pipework. They may cause fatal damage to the pump.
- If pipework directly weighs on the pump, deformation or damage may result. Be sure to install pipe supports.

### Plumbing layout

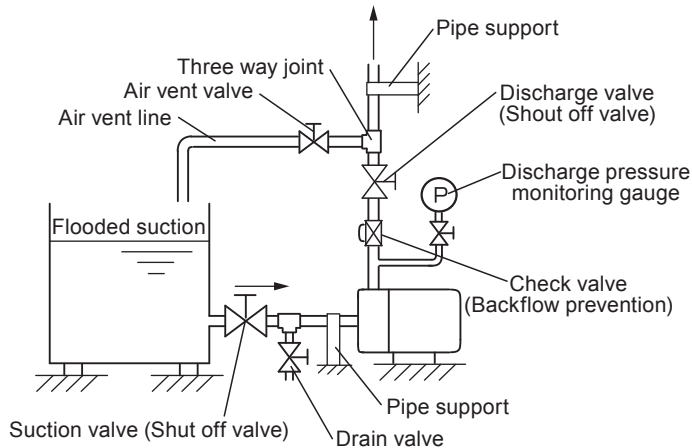

### 1. Flow/head adjustment & maintenance valves

Install a ball valve on a discharge line for flow rate adjustment and on a suction line for the convenience of maintenance, as close to the pump as possible.

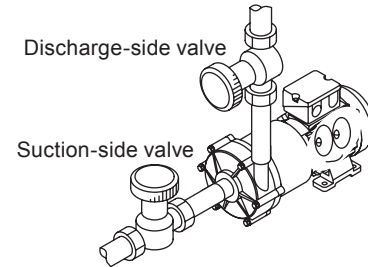

### 2. Pressure gauge

Install a pressure gauge for monitoring discharge line pressure.

### 3. Drain valve

Install a drain valve in between the pump inlet and a suction valve for blowing down liquid.

### 4. Air vent line and air vent valve

Install an air vent line and an air vent valve when a discharge line is laid long in a horizontal direction.

### 5. Check valve



Install an check valve when a discharge line is laid long in a vertical direction.

# Installation

## ■ Suction line

- Avoid any loops in a plumbing run that could form a vapour trap. A suction line should be laid on a rising gradient of 1/100 toward the pump so as to expel air easily.

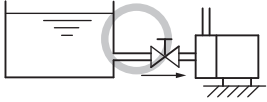
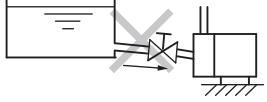
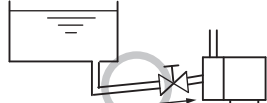
### Suction line examples

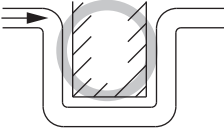
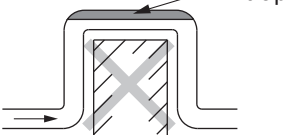
Acceptable	Unacceptable
 <p>Flooded suction</p>	 <p>Descending gradient</p>
 <p>Ascending gradient</p>	 <p>Suction lift</p>
 <p>U-shaped piping</p>	 <p>Air trap Arched piping</p>

- In order to minimize plumbing resistance, have plumbing shortest with the minimum bends. Note cavitation\*<sup>1</sup> tends to occur when plumbing length is too long.
- A liquid level should be at least 30cm higher than the tank outlet for the prevention of air ingress.
- Keep liquid in the supply tank free from foreign matters. Clean the supply tank at intervals.
- Be sure to secure connections on a suction line for the prevention of entrained air. The presence of air in a suction line may prevent liquid delivery.

## ■ Discharge line

- Piping resistance changes with properties of liquid, specific gravity, liquid temperature and pipe length, and may adversely affect pump operation when the resistance is too great. In order to minimize the piping resistance, have piping length shortest with the minimum bends. Contact us for detail.
- When a discharge line is too long, water hammer\*<sup>2</sup> phenomenon may occur and damage the pump with impact pressure when the pump stops running. Provide a check valve to prevent water hammer.

### Word & Terms:

\*1 Air bubbles caused by a negative pressure in the pump, accompanied with vibration and noise: Performance deterioration or parts corrosion results.

\*2 Shutting off a discharge line at once, liquid pressure change causes an impact pressure, accompanying impact noise and vibration. This phenomenon is called water hammer. Water hammer damages the pump & pipework and may cause leakage.

# Installation

## <Thread connection>

- Use of a Teflon pipe or a Teflon-lined pipe is recommended.
- Select a suitable pipe bore for secure connection. See page 4 for applicable connection size.
- Wrap a thread seal tape around the exposed threads of pipes, a pump inlet and outlet to create an air- and water-tightness before connection.

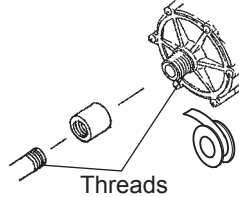

## ⚠ CAUTION

**Do not tighten a pipe too much, or a plastic inlet or outlet may break.**

## ⚠ CAUTION

**Imperfect connection on a suction line introduces air into the inside. Air ingress may cause a poor flow, dry running and consequently impeller seizing.**

- Be sure to remove a cushion from the outlet before pipework. Be careful not to damage the wet ends.

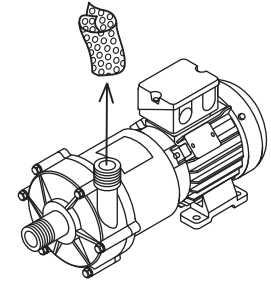

# Installation

---

## 2.3 Electrical wiring

*Electrical wiring must be done by a qualified person who has a full knowledge of safety. We are not responsible for the injury or damage accident due to nonobservance of this warning. Contact us or your nearest distributor for wiring as necessary.*

### ■ Before wiring

#### CAUTION

**Risk of electric shock. Do not handle this product with wet hands.**

#### CAUTION

**Be sure to turn off power before wiring work.**

1. Observe the power voltage, number of phases, and power frequency specified on a spec label.
2. Three phase motors rotate clockwise when U, V and W motor terminals are connected in line with R, S and T power supply terminals. The motors rotate anticlockwise if two out of these three terminal combination are interchanged.
3. In order to secure earthing, purchase an earthing wire and connect it to a screw with an engraved "E".
4. Install a leakage breaker to reduce the possibility of a fire or motor burnout.
5. Check for miswiring to reduce the risk of a short circuit or an electrical leak.



# Operation

## 1. Before operation

Read through this section before use.



### CAUTION

- Do not keep a discharge or a suction line little open or closed in operation.
- Do not open/narrow a discharge or a suction line sharply, otherwise the magnetic coupling\*<sup>1</sup> may be disconnected\*<sup>2</sup> (In this case turn off power.).
- If foreign matters enter the pump, turn off power and remove them, otherwise failure or malfunction may result.
- Do not run pump dry. If the pump runs without a liquid, the pump is damaged by friction heat.

Word & Terms:

\*1 A pair of drive and driven magnets

\*2 A state that a driven magnet (combination of impeller and magnet capsule units) does not rotate in sync with the drive magnet.

### ■ Preparations for operation

1. Check that the pump is under a flooded suction system and a liquid in a supply tank is at an appropriate level.
2. Check the connection between the pump and piping.
3. Check the pump is securely anchored.

## 2. Operation

- Do not run the pump in closed-discharge operation. Always keep the rated minimum flow rate (a tenth of the max flow rate).
- The pump should never be operated for a lengthy period (1 minute or more) with a discharge valve closed. Operation below the minimum flow can reduce lubricant and cooling effects on sliding parts. This could lead to failure.
- Do not send any medium other than fluid.
- Be sure to secure connections on a suction line for the prevention of entrained air. The presence of air in a suction line may prevent liquid delivery.
- Do not turn ON and OFF power in a short time. Before resuming operation, wait 30 minutes to turn on power after a motor has completely stopped rotating. Otherwise, motor may fail.

# Operation

## ■ Operating procedure

After installation, piping and wiring work are completed, operate the pump in accordance with the following procedures.

No.	Procedure	Points to be checked
1	Check piping, wiring and voltage.	<ul style="list-style-type: none"> <li>• See "2.2 Piping" and "2.3 Electrical wiring" sections.</li> <li>• Check the spec label to see if power supply voltage is correct.</li> </ul>
2	Open or close a valve.	<ul style="list-style-type: none"> <li>• Fully open a suction-side valve.</li> <li>• Fully close a discharge-side valve.</li> </ul>
3	Prime the pump chamber.	<ul style="list-style-type: none"> <li>• Prime the pump with liquid whether flooded suction application or suction lift application.</li> </ul> <p>Note: If the pump chamber is not filled with liquid due to residual air in it, run the pump for degassing and eliminate air completely. See "■ Degassing" on the next page.</p>
4	Supply power to the pump.	<ul style="list-style-type: none"> <li>• Check the item 1, 2 and 3. Then turn on power and start the pump.</li> </ul> <p>Note: Do not keep a discharge-side valve closed more than 1 minute.</p>

No.	Procedure	Points to be checked
5	Adjust discharge capacity & discharge head to specified level.	<ul style="list-style-type: none"> <li>• Open a discharge-side valve gradually till a flow and a head reach a specified level. <u>Do not open or close the valve sharply.</u></li> </ul> <p>Note: Check that the pump transfers a liquid without trouble. If there is a problem, turn off power immediately and solve causes. See "<b>Troubleshooting</b>" section.</p>
6	Points to be checked during operation	<ul style="list-style-type: none"> <li>• Do not allow foreign matters to enter the pump. Foreign matters may cause an impeller to be locked, hindering liquid circulation. In this case turn off power immediately (Contact us).</li> <li>• Turn off power when a leakage breaker operates. Investigate a root cause on the basis of the Trouble shooting section.</li> </ul>

# Operation

## ■ Degassing

Open a discharge line. The end of the line immersed in liquid is not ideal for degassing. Take it out from liquid as necessary. Then run the pump for one second. Repeat the one-second operation from three to five times to expel air completely.

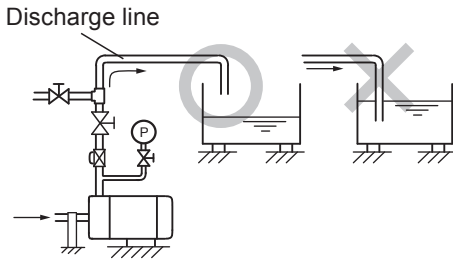

If an air vent line is laid on, open it instead of a discharge line before degassing.

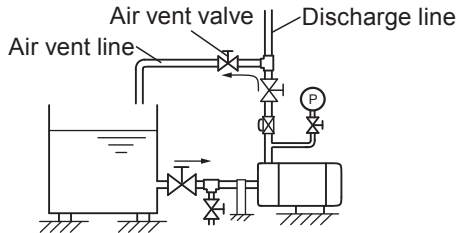

## ■ Shutdown

No.	Procedure	Description
1	Close a discharge-side valve.	Close a discharge-side valve gradually. Do not cause sudden closure by using a solenoid valve.
2	Turn off power.	Check if a motor stops rotating smoothly as turning off power. If it is not smooth, check the motor. Contact us for detail.

## ■ Before a long period of storage

Empty the pump before it is stored for a long time. In addition, run the pump with clean water for 5 minutes every 3 months to prevent the motor bearing from being stuck.

Follow "■ Operating procedure" on page 16 for resuming operation.

# Maintenance

## 1. Trouble shooting

Upon sensing abnormality, stop operation immediately and remove problems according to this section.

If the following measures do not help removing problems, contact us or your nearest distributor.

Phenomenon	The pump does not run.	Poor discharge head	Overcurrent	Noise and vibration problem	Leakage	Measure
Causes						
Wrong wiring	<input type="radio"/>		<input type="radio"/>			Inspect wiring. Rewire as necessary.
Motor failure	<input type="radio"/>		<input type="radio"/>			Contact us.
Air is trapped.		<input type="radio"/>		<input type="radio"/>		Eliminate air.
Air suction from the inlet		<input type="radio"/>				Check suction piping.
Dry running		<input type="radio"/>	<input type="radio"/>	<input type="radio"/>		Prime the pump before operation.
Too high SG or viscosity	<input type="radio"/>	<input type="radio"/>	<input type="radio"/>			Replace with suitable pump.
Impeller magnet hits the rear casing.		<input type="radio"/>	<input type="radio"/>	<input type="radio"/>		Contact us.
Impeller is damaged.	<input type="radio"/>	<input type="radio"/>	<input type="radio"/>	<input type="radio"/>		Contact us.
Foreign matters on the impeller.		<input type="radio"/>	<input type="radio"/>	<input type="radio"/>		Contact us.
O ring is damaged.					<input type="radio"/>	Contact us
Pump head mounting screws are loose.		<input type="radio"/>			<input type="radio"/>	Tighten the mounting screws.

## 2. Maintenance & Inspection

Handling of the pump, maintenance and inspection should be carried out within this instruction manual. Do not handle the pump beyond the descriptions in this manual.

We are not responsible for any personal injury or property damage due to nonobservance of this warning. Contact us or your nearest distributor as necessary.

### 2.1 Maintenance

#### ■ Retightening

After a long period of operation or storage, the pump head mounting screws may be loose. Tighten the mounting screws as necessary, but then do not deform the plastic pump head.

Tightening torque

MD-55F	3.0N•m
MD-100F	3.5N•m

#### ■ Use with an earth leakage breaker

When an earth leakage breaker is used and it has worked, always solve the root cause of problems. Be sure to unplug the pump before investigation.

# Maintenance

---

## 2.2 Inspection

### ■ Daily inspection

Always check for abnormality in vibration, noise, current value, and discharge capacity. Stop operation on sensing abnormality. And solve problems on the trouble shooting section.

### ■ Cleaning

Periodically flush the inside of a supply tank and piping with water to keep clean conditions.

Turn off power before cleaning the pump exterior. Wait until the pump cools down if it is right after operation. Wet a cloth with tap water and wring it out for cleaning the pump. Use a neutral detergent for greasy dirt and then rub with a dry cloth.

Check the pump exterior is dried before a restart.

### CAUTION

**Do not clean the pump with solvents such as benzine, alcohol and thinner. This may discolour the pump.**

### CAUTION

**Risk of electrical shock or short circuit. Do not wet a motor or electrical wiring.**

### ■ Wear parts

To run the pump for a long period, wear parts such as an impeller and an O ring need to be replaced periodically.

Contact your distributor for detail.

### ■ Before a long period of storage

Turn off power and empty the pump completely. Protect the pump from dust with a cover as necessary.

Do not store the pump under any of the following conditions.

- Under a flammable atmosphere
- Under a corrosive atmosphere
- Ambient temperature exceeds 40°C.
- Ambient temperature falls below 0°C.
- Under a dusty or humid space.
- Under direct sunlight
- Under wind and rain
- Under vibration

# Maintenance

## 3. Drainage

No drain port is provided to this pump. See drainage procedure below.

### WARNING

- Turn off power before work.
- Always wear protective clothing such as safety goggles and protective gloves during pipework or dismantlement.

### CAUTION

- A liquid flows out when detaching a pipe from the pump. Be careful not to wet electrical parts including a motor.
- Do not drain a harmful chemical liquid directly on the ground or the floor. Always use a container.
- Do not wet the motor that is not dust- or water-proof with chemical liquid. Do not power on the motor once the pump has got wet.

\*Dilute and flush out harmful liquid before removing a pipe.

### ■ Procedure

1. Turn off power. Make sure no one turns on power while working on the pump.
2. Close a discharge and a suction valve fully. Open a drain valve to empty the pump. Note liquid can not be removed completely through the drain valve.
3. Place a container under the pump and then remove a discharge and a suction line from the pump.

### CAUTION

**Be careful not to get wet with chemical liquid.**

4. Unfix and take out the pump.
5. Direct the inlet downwards to run off liquid in a container.

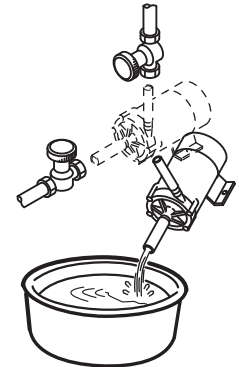
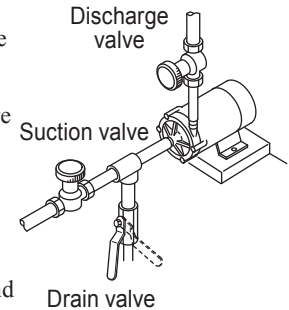





( )Country codes  
**IWAKI CO.,LTD.** 6-6 Kanda-Sudacho 2-chome Chiyoda-ku Tokyo 101-8558 Japan  
 TEL:(81)3 3254 2935 FAX:3 3252 8892(<http://www.iwakipumps.jp>)

<b>Australia</b>	<b>IWAKI Pumps Australia Pty. Ltd.</b>	TEL: (61)2 9899 2411	FAX: 2 9899 2421	<b>Italy</b>	<b>IWAKI Europe GmbH, Italy Branch</b>	TEL: (39)0444 371115	FAX: 0444 335350
<b>Austria</b>	<b>IWAKI EUROPE GmbH</b>	TEL: (49)2154 92540	FAX: 2154 9254 48	<b>Korea</b>	<b>IWAKI Korea Co.,Ltd.</b>	TEL: (82)2 2630 4800	FAX: 2 2630 4801
<b>Belgium</b>	<b>IWAKI Belgium n.v.</b>	TEL: (32)1367 0200	FAX: 1367 2030	<b>Malaysia</b>	<b>IWAKIm Sdn. Bhd.</b>	TEL: (60)3 7803 8807	FAX: 3 7803 4800
<b>China</b>	<b>IWAKI Pumps (Shanghai) Co., Ltd.</b>	TEL: (86)21 6272 7502	FAX: 21 6272 6929	<b>Norway</b>	<b>IWAKI Norge AS</b>	TEL: (47)23 38 49 00	FAX: 23 38 49 01
<b>China</b>	<b>IWAKI Pumps (Guangdong) Co., Ltd.</b>	TEL: (86)750 3866228	FAX: 750 3866278	<b>Singapore</b>	<b>IWAKI Singapore Pte. Ltd.</b>	TEL: (65)6316 2028	FAX: 6316 3221
<b>China</b>	<b>GFTZ IWAKI Engineering &amp; Trading (Guangzhou)</b>	TEL: (86)20 8435 0603	FAX: 20 8435 9181	<b>Spain</b>	<b>IWAKI Europe GmbH, Spain Branch</b>	TEL: (34)93 37 70 198	FAX: 93 47 40 991
<b>China</b>	<b>GFTZ IWAKI Engineering &amp; Trading (Beijing)</b>	TEL: (86)10 6442 7713	FAX: 10 6442 7712	<b>Sweden</b>	<b>IWAKI Sverige AB</b>	TEL: (46)8 511 72900	FAX: 8 511 72922
<b>Denmark</b>	<b>IWAKI Nordic A/S</b>	TEL: (45)48 24 2345	FAX: 48 24 2346	<b>Switzerland</b>	<b>IP Service SA</b>	TEL: (41)26 674 9300	FAX: 26 674 9302
<b>Finland</b>	<b>IWAKI Suomi Oy</b>	TEL: (358)9 2745810	FAX: 9 2742715	<b>Taiwan</b>	<b>IWAKI Pumps Taiwan Co., Ltd.</b>	TEL: (886)2 8227 6900	FAX: 2 8227 6818
<b>France</b>	<b>IWAKI France S.A.</b>	TEL: (33)1 69 63 33 70	FAX: 1 64 49 92 73	<b>Taiwan</b>	<b>IWAKI Pumps Taiwan (Hsin-chu) Co., Ltd.</b>	TEL: (886)3 573 5797	FAX: (886)3 573 5798
<b>Germany</b>	<b>IWAKI EUROPE GmbH</b>	TEL: (49)2154 9254 0	FAX: 2154 9254 48	<b>Thailand</b>	<b>IWAKI (Thailand) Co., Ltd.</b>	TEL: (66)2 322 2471	FAX: 2 322 2477
<b>Holland</b>	<b>IWAKI Europe GmbH, Netherlands Branch</b>	TEL: (31)547 293 160	FAX: 547 292 332	<b>U.K.</b>	<b>IWAKI Pumps (UK) LTD.</b>	TEL: (44)1743 231363	FAX: 1743 366507
<b>Hong Kong</b>	<b>IWAKI Pumps Co., Ltd.</b>	TEL: (852)2 607 1168	FAX: 2 607 1000	<b>U.S.A.</b>	<b>IWAKI AMERICA Inc.</b>	TEL: (1)508 429 1440	FAX: 508 429 1386
<b>Indonesia</b>	<b>IWAKI Singapore (Indonesia Branch)</b>	TEL: (62)21 690 6606	FAX: 21 690 6612	<b>Vietnam</b>	<b>IWAKI pumps Vietnam Co., Ltd.</b>	TEL: (84)813 933456	FAX: 613 933399